



This addendum accompanies your equipment documentation and is additional information concerning the heart rate features for your equipment and console.

Important

*The heart rate features are intended for reference only. They may not be accurate for every user or at every speed and are not intended for use as a medical device. Holding the heart rate handle touch sensor while exercising at higher intensity may also decrease accuracy of the heart rate reading and is not recommended. Please also read your product documentation and visit:
www.precor.com/en-us/customer-service/faq.*

Operating and Maintaining the P30 Console



Operating and Maintaining the P30 Console

PRECOR®

Edition Information

OPERATING AND MAINTAINING THE P30 CONSOLE

P/N 301096-301 rev E

Copyright © December 2012 Precor Incorporated. All rights reserved. Specifications subject to change without notice.

Trademark Note

Precor, AMT, EFX, and Preva are registered trademarks of Precor Incorporated. Other names in this document may be the trademarks or registered trademarks of their respective owners.

Intellectual Property Notice

All rights, title, and interests in and to the software of the Preva Business Suite, the accompanying printed materials, any copies of such software, and all data collected via the Preva Business Suite, are exclusively owned by Precor or its suppliers, as the case may be.

Precor is widely recognized for its innovative, award-winning designs of exercise equipment. Precor aggressively seeks U.S. and foreign patents for both the mechanical construction and the visual aspects of its product design. Any party contemplating the use of Precor product designs is hereby forewarned that Precor considers the unauthorized appropriation of its proprietary rights to be a very serious matter. Precor will vigorously pursue all unauthorized appropriation of its proprietary rights.

Precor Incorporated
20031 142nd Ave NE, P.O. Box 7202
Woodinville, WA 98072-4002
1-800-347-4404

<http://www.precor.com>

Important Safety Instructions

Important: Save these instructions for future reference.

Read all instructions in the documentation provided with your exercise equipment, including all assembly guides, user guides, and owner's manuals, before installation of this device.

Note: This product is intended for commercial use.

The display apparatus (hereinafter referred to as the *console*) is intended to be shipped with new Precor exercise equipment (hereinafter referred to as the *base unit*). It is not packaged for individual sale.

WARNING To prevent injury, the console must be attached securely to the base unit following all assembly and installation instructions shipped with the base unit. The console is intended to be connected to AC mains power through the furnished power supply ONLY. It should be powered on only when installed as described in the assembly and installation instructions shipped with the base unit. The console is intended for use only with Precor fitness equipment, not as a standalone device.

Safety Precautions

Always follow basic safety precautions when using this equipment to reduce the chance of injury, fire, or damage. Other sections in this manual provide more details of safety features. Be sure to read these sections and observe all safety notices. These precautions include the following:

- Read all instructions in this guide before installing and using the equipment and follow any labels on the equipment.

- Make sure all users see a physician for a complete physical examination before they begin any fitness program, particularly if they have high blood pressure, high cholesterol or heart disease; have a family history of any of the preceding conditions; are over the age of 45; smoke; are obese; have not exercised regularly in the past year; or are taking any medication.

French equivalent of the above notice, for Canadian markets: *Il est conseillé aux utilisateurs de subir un examen médical complet avant d'entreprendre tout programme d'exercice, en particulier s'ils souffrent d'hypertension artérielle, ou de cardiopathie ou ont un taux de cholestérol élevé, s'ils ont des antécédents familiaux des précédentes maladies, s'ils ont plus de 45 ans, s'ils fument, s'ils sont obèses, s'ils n'ont pas fait d'exercices réguliers au cours de l'année précédente ou s'ils prennent des médicaments. Si vous avez des étourdissements ou des faiblesses, arrêtez les exercices immédiatement.*

- Do not allow children, or people unfamiliar with the operation of this equipment, on or near it. Do not leave children unsupervised around the equipment.
- Make sure all users wear proper exercise clothing and shoes for their workouts and avoid loose or dangling clothing. Users should not wear shoes with heels or leather soles, and they should check the soles of their shoes to remove any dirt and embedded stones. They should also tie long hair back.
- Never leave the equipment unattended when it is plugged in. Unplug the equipment from its power source when it is not in use, before cleaning it, and before providing authorized service.

Note: The optional power adapter is considered a power source for self-powered equipment.

- Use the power adapter provided with the equipment. Plug the power adapter into an appropriate, grounded power outlet as marked on the equipment.
- Care should be taken when mounting or dismounting the equipment.
- For Treadmills: Do not use typing or web surfing features while walking at speeds that exceed a **slow and relaxed leisurely pace**. Always stabilize yourself by holding a stationary handle bar while using typing or web surfing features.

- For AMT and EFX: Always stabilize yourself by holding a stationary handle bar while using typing or web surfing features.
- Read, understand, and test the emergency stop procedures before use.
- Keep the power cord or optional power adapter and plug away from heated surfaces.
- Route power cables so that they are not walked on, pinched, or damaged by items placed upon or against them, including the equipment itself.
- Ensure the equipment has adequate ventilation. Do not place anything on top of or over the equipment. Do not use on a cushioned surface that could block the ventilation opening.
- Assemble and operate the equipment on a solid, level surface.
- **SPACING**—The below minimum spacing recommendations are based on a combination of the ASTM (U.S.) voluntary standards and EN (European) regulations as of October 1, 2012, for access, passage around, and emergency dismount:
 - **Treadmills**—a minimum of 0.5 m (19.7 in.) on each side of the treadmill and 2 m (78 in.) behind the machine.
 - **Cardio equipment other than treadmills**—a minimum of 0.5 m (19.7 in.) on at least one side, and 0.5 m (19.7 in.) behind or in front the machine.

Careful consideration should be given to the requirements of the Americans with Disabilities Act (ADA), US Code 28 CFR (see Section 305). ASTM standards are voluntary and may not reflect current industry standards. The actual area for access, passage around, and emergency dismount is the responsibility of the facility. The facility should consider the total space requirements for training on each unit, voluntary and industry standards, and any local, state, and federal regulations. Standards and regulations are subject to change at any time.

Important: *These spacing recommendations should be used when positioning equipment away from sources of heat, such as radiators, heat registers, and stoves. Avoid temperature extremes.*

- Keep equipment away from water and moisture. Avoid dropping anything on or spilling anything inside the equipment to prevent electric shock or damage to the electronics.
- When using the treadmill, always attach the safety clip to your clothing before beginning your workout. Failure to use the safety clip may pose a greater risk of injury in the event of a fall.
- Keep in mind that heart rate monitors are not medical devices. Various factors, including the user's movement, may affect the accuracy of the heart rate readings. The heart rate monitors are intended only as exercise aids in determining heart rate trends in general.
- Do not operate electrically powered equipment in damp or wet locations.
- Never operate this equipment if it has a damaged cord or plug, if it is not working properly, or if it has been dropped, damaged, or exposed to water. Call for service immediately if any of these conditions exist.
- Maintain the equipment to keep it in good working condition, as described in the *Maintenance* section of the owner's manual. Inspect the equipment for incorrect, worn, or loose components, and then correct, replace or tighten prior to use.
- If you plan to move the equipment, obtain help and use proper lifting techniques.
- Equipment Weight Restrictions: Do not use the treadmill if you weigh more than 500 pounds (225 kg). If you weigh more than 350 pounds (160 kg), do not run on the treadmill. For all other fitness equipment, the weight limit is 350 pounds (160 kg).
- Use the equipment only for its intended purpose as described in this manual. Do not use accessory attachments that are not recommended by Precor. Such attachments may cause injuries.
- Do not operate the equipment where aerosol (spray) products are being used or where oxygen is being administered.
- Do not use outdoors.
- Do not attempt to service the equipment yourself, except to follow the maintenance instructions in the owner's manual.
- Never drop or insert objects into any opening. Keep hands away from moving parts.

- Do not set anything on the stationary handrails, handlebars, control console, or covers. Place liquids, magazines, and books in the appropriate receptacles.
- Do not lean on or pull on the console at any time.

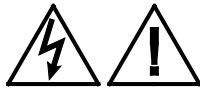

CAUTION: DO NOT remove the cover, or you may risk injury due to electric shock. Read the assembly and maintenance guide before operating. There are no user-serviceable parts inside. Contact Customer Support if the equipment needs servicing. For use with single phase AC power only.

Hazardous Materials and Proper Disposal

The batteries within self-powered equipment contain materials that are considered hazardous to the environment. Federal law requires proper disposal of these batteries.

If you plan to dispose of your equipment, contact Precor Commercial Products Customer Support for information regarding battery removal. Refer to *Obtaining Service*.

Product Recycling and Disposal

This equipment must be recycled or discarded according to applicable local and national regulations.

Product labels, in accordance with European Directive 2002/96/EC concerning waste electrical and electronic equipment (WEEE), determine the framework for the return and recycling of used equipment as applicable throughout the European Union. The WEEE label indicates that the product is not to be thrown away, but rather reclaimed upon end of life per this Directive.

In accordance with the European WEEE Directive, electrical and electronic equipment (EEE) is to be collected separately and to be reused, recycled, or recovered at end of life. Users of EEE with the WEEE label per Annex IV of the WEEE Directive must not dispose of end of life EEE as unsorted municipal waste, but use the collection framework available to customers for the return, recycling, and recovery of WEEE. Customer participation is important to minimize any potential effects of EEE on the environment and human health due to the potential presence of hazardous substances in EEE. For proper collection and treatment, refer to *Obtaining Service*.

Regulatory Notices for Cardiovascular Exercise Equipment

The regulatory information in this section applies to the exercise equipment and its control console.

Safety Approvals for Cardiovascular Equipment

Precor equipment has been tested and found to comply with the following applicable safety standards.

Cardiovascular Type Equipment:

- CAN/CSA, IEC, EN 60335-1 (Household and similar electrical appliances - Safety)
- EN 957 (Stationary training equipment, class S/B compliant equipment)

Radio Frequency Interference (RFI)

This Precor exercise equipment conforms to the following national standards defining acceptable limits for radio frequency interference (RFI).

Federal Communications Commission, Part 15

This equipment has been tested and found to comply with the limits for a Class A digital device, pursuant to Part 15 of the FCC Rules. These limits are designed to provide reasonable protection against harmful interference in a commercial installation. The equipment generates, uses, and can radiate radio frequency energy and, if not installed and used in accordance with the owner's manual instructions, can cause harmful interference to radio communications.

Operation is subject to the following two conditions: (1) this device may not cause harmful interference, and (2) this device must accept any interference received, including interference that may cause undesired operation.

WARNING Per FCC rules, changes or modifications not expressly approved by the manufacturer could void the user's authority to operate the equipment.

Industry Canada

This device complies with RSS-210:2007 of the Spectrum Management & Telecommunications Radio Standards Specification. Operation is subject to the following two conditions: (1) this device may not cause harmful interference, and (2) this device must accept any interference received, including interference that may cause undesired operation.

This Class A digital apparatus complies with Canadian ICES-003.

Cet appareil numérique de la classe A est conforme à la norme NMB-003 du Canada.

ATTENTION: Haute Tension
Débranchez avant de réparer

European Applications

CE compliance is claimed to the following directives:

- 2004/108/EC EMC Directive
- 2006/95/EC LVD Directive
- 2002/95/EC RoHS Directive

Directive compliance has been verified to the following standards:

- EN 55022
- EN 55024
- EN 60335-1
- EN 60065 (P80 and PVS)

Electrical Recommendations: 120 V and 240 V Treadmills

Note: This is a recommendation only. NEC (National Electric Code) guidelines or local region electric codes must be followed.

You should have received a power cable that meets your local electrical code requirements along with the equipment. Precor treadmills must be connected to a 20 amp individual branch circuit that can be shared only with one PVS. If you need additional help with the power connections contact your Precor authorized dealer.

Important: An individual branch circuit provides a hot conductor and neutral conductor to a receptacle. The conductors must not be looped, "daisy-chained", or connected to any other conductors. The circuit must be grounded according to NEC guidelines or local region electric codes.

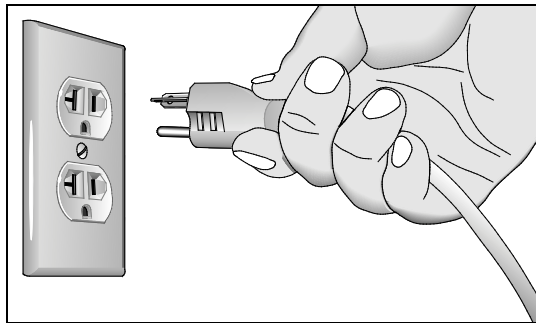

Figure 1: North American 120-volt, 20-amp power receptacle

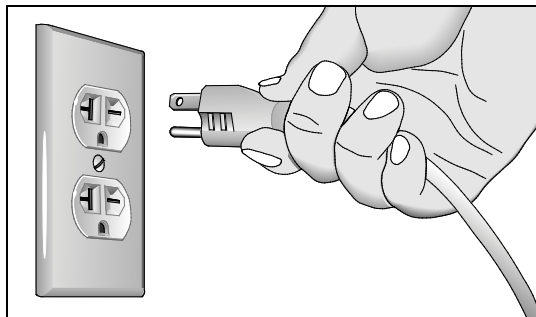

Figure 2: North American 240-volt, 20-amp power receptacle

Electrical Recommendations: All Equipment Excluding Treadmills

Note: This is a recommendation only. NEC (National Electric Code) guidelines or local region electric codes must be followed.

For equipment fitted with a P80 console or Personal Viewing System (PVS) screen a separate power connection is required. For a 20 amp branch circuit up to 10 screens can be connected. If the branch circuit has any other devices plugged into the circuit, then the number of screens must be reduced by the wattage of the other devices.

Note: The typical splitter power cords that have IEC-320 C13 and C14 plugs have a recommended maximum capacity of five screens.

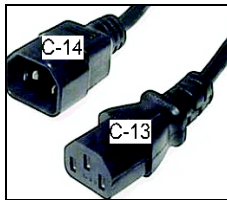

Figure 3: IEC-320 C13 and C14 plugs

Obtaining Service

Do not attempt to service the equipment except for maintenance tasks. If any items are missing, contact your dealer. For more information regarding customer support numbers or a list of Precor authorized service centers, visit the Precor web site at <http://www.precor.com>.

Table of Contents

Important Safety Instructions	3
Safety Precautions.....	3
Hazardous Materials and Proper Disposal.....	7
Product Recycling and Disposal	7
Regulatory Notices for Cardiovascular Exercise Equipment.....	8
Electrical Recommendations: 120 V and 240 V Treadmills	9
Electrical Recommendations: All Equipment Excluding Treadmills.....	11
Obtaining Service.....	11
Getting Started	15
Activating the Console for Self-Powered Equipment	15
Identifying Parts of the Console.....	17
Setting Up the Console	21
System Settings.....	21
Setting Club Parameter Values.....	23
Viewing the Informational Displays	27
User ID Entry with CSAFE Equipment.....	32
Introducing Users to the P30 Console.....	33
Using the Touch Heart Rate Feature	33
Using a Chest Strap Transmitter	35
Using the Treadmill Safety Clip	35
Treadmill Auto Stop™ (Automatic Stop) Function.....	37
Starting a Workout	39
Starting a Preset Programmed Workout.....	39
Setting Options.....	40
Pausing and Resuming an Exercise Session	41
Ending a Session.....	42
Programs	44
Maintenance	47
Cleaning the Console and Display	47
Changing the Belt (Newer Model AMT Only).....	48

Getting Started

The P30 console offers administrators the ability to set default values that meet their specific needs. These settings include items like language, units of measure, and setting a maximum allowed workout time for each piece of equipment.

Activating the Console for Self-Powered Equipment

Precor equipment is either self-powered or externally powered using an optional power adapter. Self-powered equipment requires the user exercise to initialize the console. This section provides more detail about powering equipment.

Activating the Console for Self-Powered Equipment

On self-powered equipment, when a user starts exercising, the console initializes and displays the Welcome banner. A minimum rate of motion must be maintained for the Welcome banner to appear. The words PEDAL FASTER (or the equivalent message depending on the equipment type) appear in the display when the rate of motion drops below the minimum requirements.

The equipment saves its battery charge by moving into a shutdown mode. If the user does not maintain the minimum rate of motion, a 30-second shutdown process begins.

In this mode, the console displays a countdown indicator and ignores all keypresses. If no movement is detected or the rate of motion remains below the minimum, the indicator changes as the countdown continues.

Note: The user can resume exercising before the countdown period elapses and the workout will continue from the point at which it was paused.

Optional Use of the Power Adapter

An optional AC power adapter provides sustained power to the equipment. This adapter allows you to change settings without having to pedal the equipment. To purchase the power adapter, contact your dealer.

If you purchase the optional power adapter, you must also purchase the internal cable kit. The kit supplies the cable, bracket, and fasteners that connect the power adapter to the lower electronics board.

CAUTION: The internal cable kit must be installed by authorized service personnel. Do not attempt installation on your own as you could void the Precor Limited Warranty. For more information, refer to *Obtaining Service*.

Important: *If this equipment includes a P80 console, the optional power adapter and the internal cable kit must still be installed to provide continuous power to the base unit and support its internal battery.*

Once the internal cable kit is installed, you can plug the optional power adapter into the equipment. Plug the opposite end into the appropriate power source for your equipment (120 V or 240 V). Review the safety instructions found at the beginning of this manual before using the power adapter.

CAUTION: When the optional power adapter is in use, make sure that the power supply cord does not create a safety hazard. Keep it out of the way of traffic and moving parts. If the power supply cord or power conversion module is damaged, it must be replaced.

The control console functions differently when the power adapter is connected. Because the power adapter provides a constant source of power, a user can pause for brief periods without initiating shutdown procedures. When the pause time limit expires and the user has not resumed exercising, the console returns to the Welcome screen. The default pause time is 30 seconds for all fitness equipment. Refer to the manual for your control console for instructions on setting or changing the pause time limit.

Identifying Parts of the Console

The following figure provides information about the console keys. The number and actions of the console keys may differ slightly depending on the type of equipment.

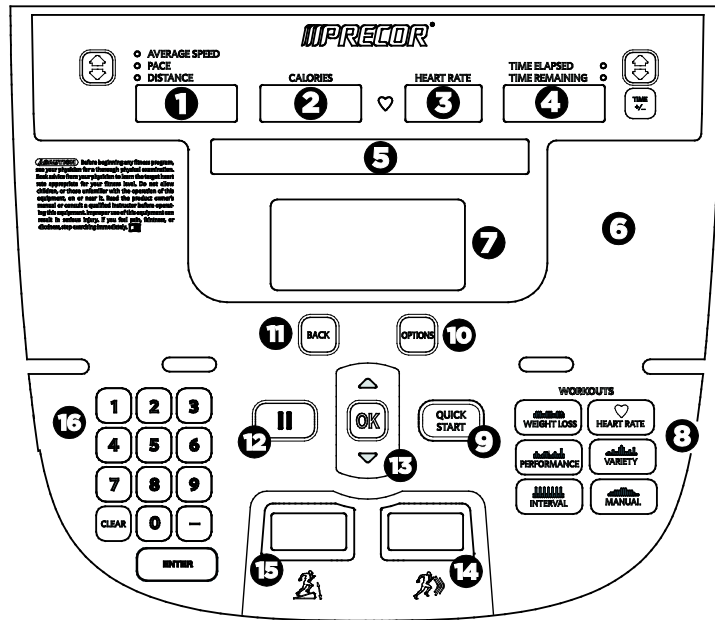

Figure 4: P30 console keys

Table 1. Parts of the console

Number	Part Name	Details
1	Average Speed Pace Distance	Use the ▲ or ▼ arrows to change which item you want to display
2	Calories	Displays the number of calories you have burned
3	Heart Rate	Displays your heart rate
4	Time Elapsed Time Remaining	Use the ▲ or ▼ arrows to change how the time is displayed
5	Upper Text Display	Scrolls information to guide the user

Number	Part Name	Details
6	<ul style="list-style-type: none"> • Muscle Monitor - EFX • Stride Length - AMT • Rate per Minute - Climber • <blank> - Bike, Treadmill 	<ul style="list-style-type: none"> • The Muscle Monitor displays the muscles used to perform that workout. • Stride Length describes the length of your steps during a workout. • Rate per Minute displays the number of meters, feet, or steps that a user has gained during a workout.
7	Lower Display	Displays graphical information about your workout progress
8	Workouts	<ul style="list-style-type: none"> • Manual • Heart Rate • Interval • Weight Loss* • Variety* • Performance* • Fat Burner - older model AMT only <p>* Not available on older model AMT</p>
9	Quick Start	Press to begin exercising

Number	Part Name	Details
10	Options	<ul style="list-style-type: none"> • Press to enter Goals, Language, Weight, Age, and Target Heart Rate information, More Options • Press More Metrics to view additional metric information <p>Metrics:</p> <ul style="list-style-type: none"> • Percent Complete • Time in Zone • Segment Time Remaining • Average Speed • Pace - Treadmill only • Calories per Minute • Calories per Hour • WATTS • METS • Target HR • Average HR • Elevations - Treadmill and climber only • Stride Length - AMT only • Show All • OFF <p>Note: If your AMT has a Metrics key, press that key to view your metrics information.</p>
11	Back	Returns user to the previous screen
12	Pause	<p>For Treadmills: Pauses treadmill during a workout.</p> <p>For Self-powered Equipment: Functions as a reset key. Pressing it stops the workout program and displays the workout summary.</p>
13	OK and Up/Down arrows	Use to navigate options and settings
14	Speed or Intensity Indicator	AMT, AMT with Open Stride™, bike, treadmill, EFX (single), and EFX (dual)

Number	Part Name	Details
15	Incline or Resistance Indicator	Treadmill, EFX (dual), climber, and AMT with Open Stride™
16	Number pad	Use to enter numerical information such as age, weight, and passwords. Press Clear to delete the numbers entered. Press Enter after you have entered numbers on this number pad.

Setting Up the Console

Use the System mode to configure settings in ways that benefit your users and your facility. The System menu is visible only to administrators and registered service technicians. Changes made to these settings are saved to the fitness equipment.

The System Settings categories are:

- Club Settings
- Informational Display

System Settings

System Setting features remain hidden from club patrons and can only be accessed using special keypresses. To view the System Settings, the equipment must be in the Welcome state and display the Welcome banner. To access the Welcome banner, you must power the equipment. For self-powered equipment, use the optional power adapter, otherwise you will have to maintain the minimum rate of motion. For more information on self-powered equipment, refer to *Activating the Console for Self-Powered Equipment*.

The equipment is in the Welcome state when it is on, but not actually in use. This means that there is no exercise session, data entry, or diagnostic operation in progress.

When the equipment is in the Welcome state:

- **PRECOR** scrolls on the lower text display. **SELECT A WORKOUT OR PRESS QUICKSTART TO BEGIN** scrolls in the upper text display.
- The heart rate signal is the only segment activated.
- On the treadmill, the belt is not moving and the lift motor is off.

Note: On self-powered equipment, the console initializes when you begin working out. You must maintain a minimum rate of motion for the Welcome banner to appear.

The changes made in System Setting modes become the default settings when the display resets to the Welcome banner.

CAUTION: If you change the Unit of Measure display on the treadmill, check the speed setting to verify that it is correct.

To view the Club Parameters settings:

1. At the Welcome banner, press **Pause**.



2. Press the following number keys in sequence to enter the password:
5 6 5 1 5 6 5
3. Press **OK**.
The Set Club Parameters banner appears.

Table 2. Navigational keys for the system setting modes

Key	Function
▲ or ▼	Navigates the settings menu
OK	Selects a menu setting
BACK	Returns to the previous menu level without saving changes
PAUSE	Exits the System Settings mode and returns to the Welcome banner

Setting Club Parameter Values

Use this information to customize the equipment for your setting.

Safety Code (Treadmill only)

Value Range: Enabled or Disabled

(Default: Disabled)

When the equipment is shipped from the factory, the safety code protection feature is disabled. If you enable the safety code, your users will need to enter a four digit number to begin their exercise session and start the running belt. The code is **1 2 3 4**.

Select Language (All Equipment)

Value Range: English, Deutsch, Espanol, Francais, Netherlands, Portugues, Rucckijj, and Italiano

(Default: English)

Select your preferred language for the console display.

Note: Programming prompts are not affected by language selection. The prompts in this section continue to appear in English.

Set Units (All Equipment)

Value Range: U.S. or Metric

(Default: U.S.)

The equipment can display measurements in either Metric or U.S. Standard.

Important: *If you change the Unit of Measure on a treadmill, be sure to check the speed setting to verify that it is correct.*

Set Max Workout Time (All Equipment)

Value Range: 1 to 240 minutes

(Default: 60 minutes)

You can set a maximum workout time per session. Choose a time limit between 1 and 240 minutes, or select **No Limit** if you do not want to set a time limit. For example, if you set the time limit to 20 minutes, users can only enter a workout time between 1 and 20 minutes.

Select **No Limit** if you do not want to set a time limit.

Note: The Military Performance Programs will not complete if the maximum exercise time limit is less than 40 minutes. Set the maximum time about 40 minutes if you have enabled these performance programs.

Set Max Pause Time (All Equipment)

Value Range: 1 to 120 seconds

(Default: 120 seconds)

This setting limits how long equipment remains in a paused banner during a workout before it resets.

Note: The optional power adapter must be connected on self-powered equipment to establish a definitive pause time limit. If the optional power adapter is not attached and the rate of motion drops below the minimum requirements, the equipment begins its 30-second shutdown, effectively eliminating pause mode.

Set Cool Down Time (All Equipment)

Value Range: 0 to 5 minutes

(Default: 5 minutes)

Select the maximum amount of time the equipment remains in the cool down mode. The cool down time is the period of time following the completion of a program when the user exercises at a reduced work rate.

Creating a Custom Workout

Value Range: ON or OFF

(Default Value: OFF)

Create a customized program for your workout.

Note: This option is not available on all equipment.

To create a custom program:

1. At the **SET CUSTOM PROGRAM** prompt, press **OK**.
The program profile appears in the display and a blinking column indicates your starting point.
2. Press the down arrow key on the navigational keypad to select the column you want to change.
3. To change the height of the column, refer to the following table.

Table 3. Custom Program keys

Equipment	Key Name	Description
Treadmill	INCLINE	Changes the column height and affects the Custom Program incline.
EFX (835 only)	INCLINE	Changes the column height and affects the Custom Program ramp incline.
Bike	RESISTANCE	Changes the column height and affects the Custom Program pedal resistance.
Climber	RESISTANCE	Changes the height of the column and affects the Custom Program step resistance.

4. When you have set the column height, press the down arrow key on the navigational keypad to move to the next column. You can press the up arrow key to return to previous columns.
5. Continue adjusting the profile for each column.

Note: Two custom programs are available on the treadmill. Some Precor products contain only one custom program. The prompt indicates which one you have accessed. To select a second custom program (treadmill only), press the down arrow key on the navigational keypad, before pressing OK in step 6.

The Set Custom Program 2 default value is **Disabled**.

6. When you have finished creating your program, press **OK** to save the program profile, and return to the Welcome banner. Press **BACK**, to exit this setting without saving your changes to the custom profile.

Set Speed Limit (Treadmill only)

Value Range: Full speed range of equipment

(Default: Maximum speed)

This setting limits how fast the running belt moves and, consequently, the number of speed settings that are available to the user. Use it to set the maximum speed that a user can enter when using the equipment.

The speed is displayed in miles per hour (mph) or kilometers per hour (kph) depending upon the units of measure (U.S. Standard or Metric) selected earlier. The speed ranges values from 0.5 to 16 mph (0.8 to 25.5 kph).

Set Incline Limit (Treadmill only)

Value Range: Full grade range of equipment

(Default: Maximum grade possible)

Set the maximum percent incline that a user can enter when using the equipment.

Hidden Programs (Treadmill only)

Value Range: Show Programs or Hide Programs

(Default: Hide Programs)

When set to **Show Programs**, all Performance Programs are available to a user through the PERFORMANCE key. These programs are: Gerkin Fitness Test, USAF PRT, NAVY PRT, ARMY PFT, USMC PFT, and Federal Law Enf. PEB.

If set to **HIDE PROGRAMS**, when the user presses **PERFORMANCE**, the message **WORKOUT NOT AVAILABLE** will scroll in the upper text display.

Set Resistance Range (Bike only)

Value Range: High, Medium, or Low

(Default: High)

You can set a low, medium, or high base resistance on the recumbent or upright bikes. There are 25 levels of resistance within each base setting, but the base setting affects the overall resistance range. The following ranges are available:

- High: Provides full resistance range.
- Medium: Provides approximately two thirds of the resistance that is available within the high group setting.
- Low: Provides approximately one third of the resistance that is available within the high group setting.

Set Crossramp Auto Level (EFX Dual only)

Value Range: 0 to 20

(Default: 10)

Use this setting to choose a specific ramp incline so that the EFX automatically returns to that incline at the end of a workout session.

Viewing the Informational Displays

Information Display settings are values that provide you with information about the equipment. Types of information contained in this setting group include, an event log, software and equipment serial numbers, and usage information.

To view the System settings:

1. At the Welcome banner, press **Pause**.



2. Press the following number keys in sequence to enter the password:

6 5

3. Press **Enter**.

Use the following table to set up customized Informational Display values.

Table 4. Informational Displays values

Product	Value	Information provided
All	ODOMETER	<p>The odometer value correlates to the type of equipment and the standard of units, U.S. or Metric, selected in the programs.</p> <ul style="list-style-type: none"> • Treadmill and newer model AMT: Displays the number of cumulative miles or kilometers logged to date. In addition, the AMT displays the number of vertical strides. • EFX: Displays the number of total strides logged to date. • Bike: Displays the number of total revolutions logged to date. • Climber: Displays the number of floors climbed.

Product	Value	Information provided
AMT - Newer Models Only	BELT USAGE	<ul style="list-style-type: none"> • Belt Stride Count: Tracks the number of strides on equipment. • Stride Count Reset: Reset increases by one each time a reset is performed. • Odometer at Last Reset: Records the odometer reading at the time the belt was changed. The equipment odometer continues to count forward after the belt change.
All	HOUR METER	<ul style="list-style-type: none"> • Displays the number of hours that the equipment has been in use. • The equipment tracks the elapsed minutes, but the value that appears is truncated to the nearest full hour.
All	UPPER BOOT SW PART NUMBER	Upper board application software part number and version
All	UPPER BASE SW PART NUMBER	Upper base application software version
All	LOWER BASE SW PART NUMBER	Lower application software version
All	METRICS BOARD	Software number on the Metrics Board
AMT	STRIDE DIAL SW PART NUMBER	Stride Dial software number
All	SERIAL NUMBER	Used to determine exact model and type of equipment
All	USAGE LOG	<ul style="list-style-type: none"> • The number of times each program has been used and displays the associated cumulative minutes. • Helpful in determining user preferences in program selection.
All	EVENT LOG	Displays any event codes that may have been detected by the software. For more information, refer to <i>Event Log</i> .

Event Log

The event log holds a maximum of 30 events. After the log reaches 30 events, older events are erased to make room for newer ones.

Each event log entry contains the following information:

- Event number
- Odometer value when the event occurred
- Hour meter value at the time the event occurred
- Current drawn by the motor when the event occurred (treadmill only)

The following table contains a list of events detectable by the software.

Table 5. Event log numbers and descriptions

Event Number	Description of Event
00	Upper PCA memory location event
02	RAM location event
03	EEPROM checksum event
05	Depressed key at power up
09	Lower PCA memory test event
10	Line Frequency out of acceptable range
11	Watchdog (Upper PCA) low voltage power
12	Watchdog (Lower PCA) low voltage power
13	Fan at incorrect speed (version 1 treadmills)
14	Fan fail (Lower PCA)
15	AC input voltage too high
16	AC input voltage too low
20	Too many maximum power requests in one second
21	Too many maximum consecutive power requests
22	No motor pulses at start up
23	Motor pulses missing after start up
24	Reduce speed requested, speed is not reducing
26	Motor pulse width incorrect
27	Too much drive motor current
28	Temperature too high

Event Number	Description of Event
29	Excessive AC input current
30	Communications event lower board to upper board
31	Incorrect Communications event upper board to lower board
32	Communication event upper board to lower board
33	Incorrect communications event lower board to upper board
37	E-STOP error (treadmill only)
40	Lift motion detected
42	Lift position value out of range
43	Zero switch not found
44	Un-commanded lift motion
45	Lift going in the wrong direction
50	Too much brake (magnet) current
53	Cannot read target, cannot find home switch
54	Target pulses lost during operation
55	Brake home switch activated unexpectedly
60	Auto Stop sensor failure (treadmill only)
61	Auto Stop not present (treadmill only)
62	Vertical sensor failure (AMT only)
70	Belt replacement, lower control board not read (AMT only)
71	Belt replacement, new lower control board (AMT only)
72	Belt replacement, lower control board version unknown (AMT only)
73	Belt replacement, lower control board record bad (AMT only)
74	Belt replacement, lower control board refurbished console (AMT only)
75	Belt replacement, refurbished lower control board (AMT only)
76	Belt replacement, console stride count is less than lower control board (AMT only)
77	Belt replacement, console stride count is greater than lower control board (AMT only)
78	Belt replacement warning (AMT only)
79	Belt replacement required (AMT only)

User ID Entry with CSAFE Equipment

This equipment is fully compatible with CSAFE protocols. When the equipment is connected to a CSAFE master device, the user is prompted to press ENTER and begin an identification process. The user ID is displayed as five zeros and indicates the starting point. The following table describes key functions while in CSAFE mode.

Table 6. CSAFE access keys

Keys	Function
Number Keypad	Use the number keys to enter a user ID. Once you have entered the user ID number, press ENTER or OK to submit the user ID.
CLEAR	Erases individual numbers in the user ID from right to left.
ENTER or OK	Submits the user ID. Note: User ID entry is bypassed when the user enters five zeros. No workout statistics are recorded.
PAUSE	Resets to the Welcome banner.

A message appears on the display and indicates when the user ID is accepted by the CSAFE master device. Once program selection is complete, the user can begin exercising.

Introducing Users to the P30 Console

CAUTION: Before beginning any fitness program, see your physician for a thorough physical examination. Seek advice from your physician to learn the target heart rate appropriate for your fitness level.

The P30 console offers an easy-to-follow display and multiple programs to help people meet their exercise needs.

Important: Please review the following sections in this guide with your users before allowing them to use the fitness equipment:

- *Important Safety Instructions*
- *Getting Started*
- *Using the Safety Clip (for treadmill only)*

Using the Touch Heart Rate Feature

Note: Touch heart rate performance may vary based on a user's physiology, fitness level, age, and other factors. You may experience an erratic readout if your hands are dry, dirty, or oily, or if the skin on your palms is especially thick. Wearing hand lotion can also cause an erratic readout. In addition, make sure that the sensors are clean to ensure proper contact can be maintained.

To use the touch heart rate feature, place the palm of your hands directly on the metal heart rate sensors on the equipment's handlebars. To ensure an accurate heart rate readout, make sure you follow these tips:

- Both hands must grip the sensors for your heart rate to register.
- It takes a number of consecutive heartbeats (15-20 seconds) for your heart rate to register.

- When gripping the sensors, do not grip tightly. Keep a loose, cupping hold. Holding the grips tightly can affect the reading.
- As you work out, your perspiration will help transmit your heart rate signal. If you have difficulty using the handheld grips to determine your heart rate, try the sensors again later in the workout to see if you can obtain a heart rate signal.
- If the touch heart rate feature does not work for you, Precor recommends that you use a chest transmitter strap.

Heart Rate Target Zones

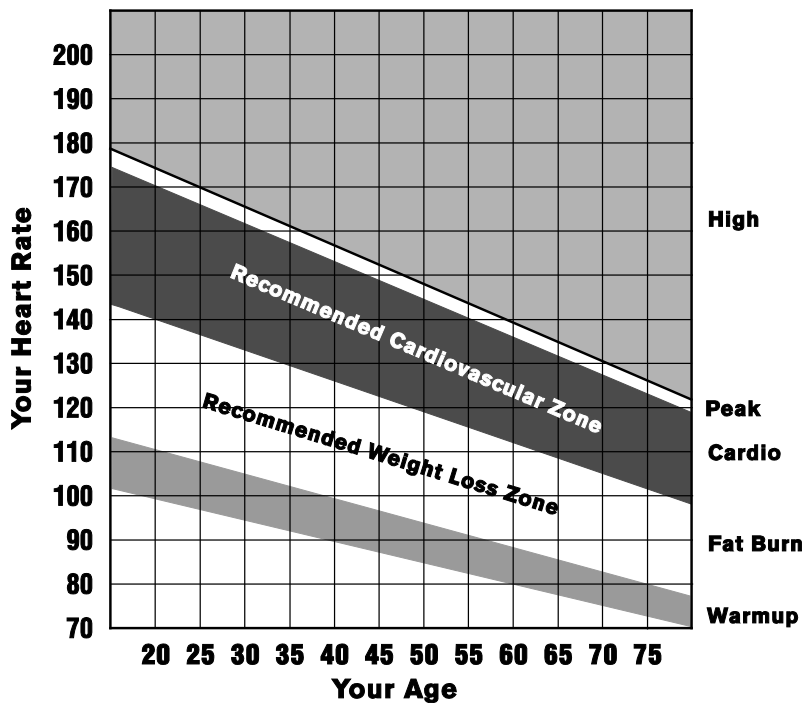

Figure 5: Heart rate target zones

CAUTION: Your heart rate should never exceed 85% of your maximum aerobic heart rate. Your maximum heart rate is equal to 220 minus your age.

Using a Chest Strap Transmitter

WARNING Signals used by the Chest Strap Transmitter (or heart rate strap) may interfere with pacemakers or other implanted devices. Consult your physician and the manufacturers of your Chest Strap Transmitter and implanted device before using a Chest Strap Transmitter.

Wearing a chest strap transmitter during your workout provides steady heart rate information. For the equipment to detect your heart rate, you must grip the touch heart rate sensors or wear a chest strap transmitter while exercising. In the presence of both touch and wireless data, the touch data takes precedence and will display.

Note: To receive an accurate reading, the strap needs to be in direct contact with the skin on the lower sternum (just below the bust line for women).

To use a chest strap transmitter:

1. Carefully dampen the back of the strap with tap water.
Important: Do not use deionized water. It does not have the proper minerals and salts to conduct electrical impulses.
2. Adjust the strap and fasten it around your chest. The strap should feel snug, not restrictive.
3. Make sure that the chest strap is right-side-up, lies horizontally across, and is centered in the middle of your chest.
4. Test the chest strap placement by checking the heart rate function on the equipment. If a heart rate is registering, your chest strap placement is correct. If the equipment does not register a heart rate, readjust the strap and recheck the heart rate function.

Using the Treadmill Safety Clip

The treadmill is equipped with two different stop functions, which behave as follows:

<i>If the user ...</i>	<i>Then the treadmill belt ...</i>	<i>And the console ...</i>
Presses down on the red STOP button 2	Slows to a stop	Shows that the exercise workout is paused
Pulls on the lanyard attached to the safety clip and trips the restart switch 1	Slows to a stop	Shows the words PUSH TO RESET SWITCH and an arrow pointing to the Restart switch

The restart switch is located just below the console and immediately behind the red **STOP** button, as shown in the following figure. When it is tripped, the bar pops up, displaying the words **PUSH TO RESET SWITCH** on its front side. The treadmill does not operate while these words are visible.

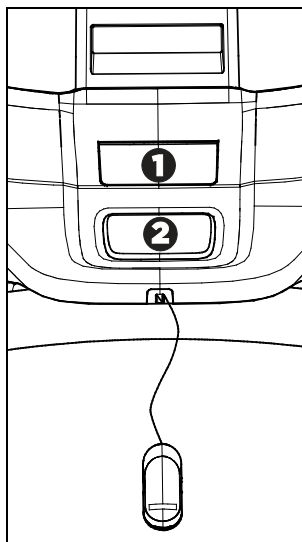

Figure 6: Restart switch

Instruct users on how important it is to use the safety clip while exercising on the treadmill, and demonstrate how they should attach it to their clothing near the waistline.

If the restart switch trips during exercise, perform the following steps:

1. Reattach the safety clip if necessary.
2. Press the restart switch down until it clicks, returning it to its normal position.

Note: If the restart switch trips, all information about the current workout is deleted.

3. Start the workout from the beginning, reducing the time as needed to account for the amount of exercise that has been completed.

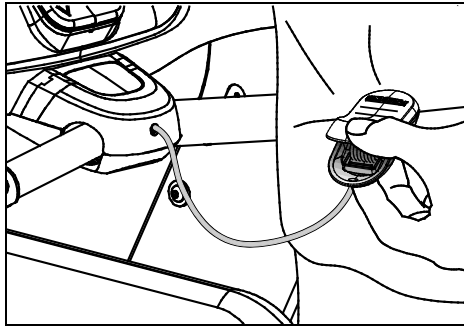

Figure 7: Attaching the safety clip

Treadmill Auto Stop™ (Automatic Stop) Function

Important: *The default setting for this feature is ON. An administrator can turn off this feature in the System Settings; however, Precor recommends it remain ON.*

The Auto Stop™ (Automatic Stop) feature is designed to bring the treadmill to a gradual stop when it is not in use. This might occur if a user steps off the treadmill before the end of a workout and leaves the treadmill running.

Sixty seconds after a treadmill workout starts or resumes, the equipment begins Auto Stop monitoring. If a user is detected, then no message appears, and the selected workout continues.

If no user is detected after an additional 30 seconds, the console displays the message **NO USER DETECTED, STOPPING IN 10 SECONDS** as notification of the pending stop. During the display of this message, a ten second countdown begins. If a user does not override the countdown, the belt comes to a gradual stop after the countdown is complete.

Note: Users weighing more than 90 pounds (41 kg) are detected within the speed and position limits of the feature. Users weighing 50 pounds (22.7 kg) to 89 pounds (40.5 kg) may not be detected depending on their speed and location. Always be aware of and follow the console's instructions for proper operation.

Starting a Workout

CAUTION: If you are using a treadmill, be sure to attach the security clip to your clothing before starting your workout.

The equipment is in the Welcome state when the words **SELECT A WORKOUT OR PRESS QUICKSTART TO BEGIN** scroll across the scrolling upper text display and **PRECOR** scrolls on the lower text display.

If the equipment is connected to CSAFE, the words **SELECT A WORKOUT, PRESS QUICKSTART, OR ENTER TO BEGIN** scroll across the upper text display.

If anything else appears on the screen, press **Pause** to display the Welcome banner.

From this screen, there are two ways to begin a workout:

- Press **Quick Start™**.
This action launches the Manual program. Calculations, such as calories used, are based on a 150-lb (68 kg), 35-year old individual. You can complete a workout using this program with default values, or you can change workout settings.
- Press one of the preset workouts.

When a user reaches the club time limit during a workout, the workout limit in minutes appears before the words **CLUB TIME LIMIT REACHED, WORKOUT ENDING**, appear in the upper text display.

Starting a Preset Programmed Workout

Preset workouts are a great way to tailor your workouts to your fitness goals, stay challenged, and add variety to your sessions. Most P30 equipment contains multiple preset workouts. These workouts include:

- Manual
- Heart Rate
- Interval
- Weight Loss (Fat Burner on older model AMT)
- Variety
- Performance

Climber-specific programs are:

- City Steps
- Fat Burn
- Rolling Hill
- Steady Climb
- Pyramid

Setting Options

Goal, Language, and Unit options can be set before you begin a workout. Once you begin a workout or press Quick Start, you can also enter Age and Weight, and a Target Heart Rate goal.

Note: After setting personal options, select a workout and begin exercising or your options will revert to the default values.

To choose a workout goal before you begin exercising:

1. From the Welcome banner, press **OPTIONS**.
Goal is the first option.
2. To choose the Goal option, press **OK**.
Goal options are Time, Distance, and Calories.
3. Use the Up and Down arrows or keypad to increase or decrease your time, distance, or calorie goal.
4. Once you have entered a goal, press **OK**.
5. To continue to the next option category, Press **OPTIONS** again.

To choose a language setting before you begin exercising:

1. From the Welcome banner, press **OPTIONS**.
2. Press **OPTIONS** again to choose the Language option, and press **OK**.
3. Use the Up and Down arrows to navigate the list of available languages. To select a language, press **OK**.
Language choices are: English, Deutsch, Espanol, Francais, Nederlands, Portugues, Rucckijj, and Italiano.
4. To continue to the next option category, press the **Up or Down** arrows.

To choose a unit of measure before you begin exercising:

1. From the Welcome banner, press **OPTIONS**.
2. Press **OPTIONS** twice to go to **UNITS**.
3. Use the Up and Down arrows to select a unit of measure.
4. Once you have selected a unit of measure, press **OK**.

Setting Options after You Begin a Workout

Once you begin a Quick Start workout or choose a Workout, you can enter your Weight and Age, and a Target Heart Rate goal. The Language and Units settings are also available.

To enter your Age and Weight during a workout:

1. Press **OPTIONS**.
2. Weight/Age is the first option. To choose this option, press **OK**.
3. Use the Up and Down arrows to increase or decrease your weight.
4. Once you have selected your weight, press **OK**.
5. Repeat steps 1 - 4 to enter your age.
6. To continue to the next option category, press the **Up or Down** arrows.

The Target Heart Rate option appears.

7. Enter a target heart rate goal, and press **OK**.

At this time, you can set Units and Language if you have not selected these options prior to beginning your workout.

Pausing and Resuming an Exercise Session

When you interrupt a workout, the equipment responds in one of two ways, depending on how it is powered.

Paused (Externally Powered Equipment)

When the session is paused, the belt speed is slowly reduced to zero, or the resistance is slowly reduced to the minimum. The lift motor is turned off leaving the incline or crossramp at its current position. Data entry is canceled.

When you press **Pause** on all non-treadmill equipment, it displays the summary screen with your workout metrics. After displaying the summary, it returns to the Welcome screen.

Pending Shutdown (Self-Powered Equipment)

On self-powered machines, the paused state is equivalent to the pending shutdown state. When you stop working out, the equipment begins a 30 second countdown.

The accumulated metrics (e.g., time, strides, distance, calories) hold their current values and do not change. Data entry may not be started.

To restart the program, begin working out again. The resistance is reset to what it was when the program was paused.

If the equipment remains inactive for more than 30 seconds, the power is lost and the equipment bypasses the workout summary screen.

Ending a Session

Cooling down is an important aspect of your workout because it helps reduce muscle stiffness and soreness by transporting excess lactic acid out of the working muscles. In addition, a three to five minute cool down allows your heart rate to return to its normal, resting state.

At the end of your workout, a Summary screen displays your average heart rate during your workout and your accumulated workout metrics.

If you performed a fitness test exercise program, an initial message presents a fitness score.

The next two messages display the user's average and maximum heart rate during the session. These messages are only displayed if heart rate data was acquired during the session, i.e., a valid heart rate number was displayed at least once during the session.

The summary state times out in two minutes, causing a return to the Welcome banner. If the machine is in a CSAFE Finished state then the summary state must last for at least the CSAFE timeout value, typically 10 seconds. If it has not lasted that long, then before returning to the Welcome banner, the word **RESETTING** appears until the CSAFE finished state ends.

Three different types of metrics are captured during a workout.

Controlled Metrics can be set and changed. They include:

- Resistance Level (AMT, EFX, bike)
- Speed (treadmill)
- Incline (treadmill)
- Steps/Minute (climber)

Current Performance Metrics describe the intensity of a workout in real time. They include:

- Calories/Minute, Calories/Hour
- Heart Rate
- Speed (treadmill, bike)
- Revolutions/Minute (bike)
- Strides/Minute (AMT, EFX)

Accumulated Metrics describe the overall performance throughout the entire exercise session. They include:

- Time:
 - Count-down Mode
 - Count-up Mode
- Calories
- Distance:
 - Average Strides/Minute (AMT, EFX)
 - Average Speed (treadmill, bike)
 - Floors (climber)

Programs

Preset workouts are a great way to tailor your workouts to your fitness goals, stay challenged, and add variety to your sessions. In the following figures, the elevated areas show the work expenditure for each preset program.

Manual

During this workout, resistance and speed changes are completely under your control. The profile is initially a flat line. Any increase or decrease made in one workout segment will increase or decrease all remaining portions by the same amount.

Heart Rate

This workout computes your target heart rate based on the calculation, 60% of 220 minus your age; however, you can override this value. The equipment adjusts resistance and/or incline to maintain your target heart rate while you work out.

When a heart rate signal is not received, a heart shape with a question mark appears in the upper text display. On the newer model AMT, the heart shape remains lit, but the metric display appears blank. Recheck your hand grip on the handheld sensors or the placement of your chest strap.

For the unit to detect your heart rate, you must grip the handheld heart rate sensors or wear a chest strap while exercising. In the presence of both handheld and wireless data, the handheld data takes precedence and displays.

Interval

The Interval workout is primarily for conditioning your cardiovascular system. This workout is designed to raise and lower your heart rate in a repeating fashion for a user-defined period of time by alternating rest and work intervals. Workout intensity is adjustable.

Weight Loss

The workout time is fixed at 28 minutes. The workout consists of seven four-minute intervals. You can change the resistance at any time during the work interval.

Note: This program is called Fat Burner on older AMT models.

Variety

During this workout, resistance or ramp/incline vary throughout the workout in a random pattern.

Performance

Note: When a user presses **PERFORMANCE**, the message **WORKOUT NOT AVAILABLE** will scroll in the upper text display, if the console is set to **HIDE PROGRAMS** in the Settings menu.

The Fitness Test, available by pressing the **PERFORMANCE** key, provides a means of comparing your fitness level with the official fitness test of the International Association of Firefighters (IAFF). It is written using the Gerkin Protocol, which is the basis for the official IAFF fitness test and part of their Wellness and Fitness Initiative.

During the test, the equipment gradually increases the incline and speed in specific stages. The keypads are disabled. Whatever stage you are at when the test ends determines your aerobic capacity and establishes your VO₂ max. Once you complete the test, a fitness score appears as part of the workout summary.

City Steps (Climber only)

The City Steps Program increases and decreases your step rate in stages. In each stage, the rate gradually rises to a peak and then falls quickly back to the starting rate. This pattern is repeated. You can override the settings for each column. Any increase or decrease made in one program segment will increase or decrease all remaining portions by the same amount.

Fat Burn (Climber only)

This intense program is designed to burn fat and increase cardiovascular conditioning. Step rate fluctuates mildly within a high-intensity range. Anytime during the program, you can override the settings, and the remaining profile columns will change accordingly. The changes are applied throughout the remainder of the program.

Rolling Hill (Climber only)

This cardio-conditioning program provides a high step rate. Like the Aerobic program, it involves several “peaks” and “valleys” in step rate; however, the dips in intensity during “rest” periods are smaller, resulting in more consistent intensity. You can override the settings for each column. The changes also raise or lower the columns on the remaining portion of the program profile.

Steady Climb (Climber only)

The Steady Climb program slowly increases the step rate until it culminates at the end of the program. You can override the settings for each column. The changes also raise or lower the columns on the remaining portion of the program profile.

Pyramid (Climber only)

The Pyramid Program slowly increases the step rate to a “peak” and then slowly decreases back to a slower rate. As the step rate increases, resistance is decreased and then increases as the step rate decreases. Any increase or decrease made in one program segment will increase or decrease all remaining portions by the same amount.

Maintenance

To keep the equipment functioning properly, perform the minor maintenance tasks in this section at the intervals suggested. Failure to maintain the equipment as described in this section could void the Precor Limited Warranty.

DANGER To reduce the risk of electrical shock, always disconnect the equipment from its power source before cleaning it or performing any maintenance tasks. If the equipment uses an optional power adapter, disconnect the adapter.

Cleaning the Console and Display

The console requires little maintenance once installed. Precor recommends that you clean the console before and after each exercise session.

To remove dust and dirt from the console:

- Wipe all exposed surfaces with a soft cloth that you have moistened with a solution of 30 parts of water to 1 part of Simple Green® (for more information, visit www.simplegreen.com).

Important: Do not use any acidic cleaners. Doing so will weaken the paint or powder coatings and void the Precor Limited Warranty. Never pour water or spray liquids directly on the console or console's screen.

- It is important to avoid using any corrosive chemicals on the console or screen.
- Always dampen the cloth and then clean the screen. Be sure to spray the cleaning liquid onto the cloth, not the console, so that drips do not seep into the console.
- Apply the cleaner with a soft, lint-free cloth. Avoid using gritty cloths.

Changing the Belt (Newer Model AMT Only)

The newer model AMT uses belts to provide motion. These belts eventually wear and must be replaced.

When the belt stride count reaches 90 million, the message **BELTS MUST BE CHANGED SOON** scrolls on the Welcome screen. While this message appears, the AMT operates normally.

Important: *If this message displays on your AMT, please contact Precor Customer Support for assistance.*

When the belt stride count reaches 100 million (and the belt has not been changed), the message **BELTS CHANGE REQUIRED** scrolls continuously on the Welcome screen. The input keys are not functional and the user cannot enter values or begin a workout until the belts are changed. Please contact Precor Customer Support to schedule a belt change.



Precor Incorporated
20031 142nd Avenue NE
P.O. Box 7202
Woodinville, WA USA 98072-4002



P30 OM 301096-301 rev E, en
December 2012

Assembling and Maintaining AMT[®] 800-Series Adaptive Motion Trainers[®]



PRECOR[®]

Assembling and Maintaining AMT® 800-Series Adaptive Motion Trainers®

PRECOR®

Edition Information

ASSEMBLING AND MAINTAINING AMT 800-SERIES
ADAPTIVE MOTION TRAINERS

P/N 301704-301 rev E

Copyright © October 2012 Precor Incorporated. All rights reserved. Specifications subject to change without notice.

Trademark Note

Precor, AMT, EFX, and Preva are registered trademarks of Precor Incorporated. Other names in this document may be the trademarks or registered trademarks of their respective owners.

Intellectual Property Notice

All rights, title, and interests in and to the software of the Preva Business Suite, the accompanying printed materials, any copies of such software, and all data collected via the Preva Business Suite, are exclusively owned by Precor or its suppliers, as the case may be.

Precor is widely recognized for its innovative, award-winning designs of exercise equipment. Precor aggressively seeks U.S. and foreign patents for both the mechanical construction and the visual aspects of its product design. Any party contemplating the use of Precor product designs is hereby forewarned that Precor considers the unauthorized appropriation of its proprietary rights to be a very serious matter. Precor will vigorously pursue all unauthorized appropriation of its proprietary rights.

Precor Incorporated
20031 142nd Ave NE, P.O. Box 7202
Woodinville, WA 98072-4002
1-800-347-4404

<http://www.precor.com>

Important Safety Instructions

Important: *Save these instructions for future reference.*

Read all instructions in the documentation provided with your exercise equipment, including all assembly guides, user guides, and owner's manuals, before installation of this device.

Note: This product is intended for commercial use.

The display apparatus (hereinafter referred to as the *console*) is intended to be shipped with new Precor exercise equipment (hereinafter referred to as the *base unit*). It is not packaged for individual sale.

WARNING To prevent injury, the console must be attached securely to the base unit following all assembly and installation instructions shipped with the base unit. The console is intended to be connected to AC mains power through the furnished power supply ONLY. It should be powered on only when installed as described in the assembly and installation instructions shipped with the base unit. The console is intended for use only with Precor fitness equipment, not as a standalone device.

Safety Precautions

Always follow basic safety precautions when using this equipment to reduce the chance of injury, fire, or damage. Other sections in this manual provide more details of safety features. Be sure to read these sections and observe all safety notices. These precautions include the following:

- Read all instructions in this guide before installing and using the equipment and follow any labels on the equipment.
- Make sure all users see a physician for a complete physical examination before they begin any fitness program, particularly if they have high blood pressure, high cholesterol or heart disease; have a family history of any of the preceding conditions; are over the age of 45; smoke; are obese; have not exercised regularly in the past year; or are taking any medication.

French equivalent of the above notice, for Canadian markets: *Il est conseillé aux utilisateurs de subir un examen médical complet avant d'entreprendre tout programme d'exercice, en particulier s'ils souffrent d'hypertension artérielle, ou de cardiopathie ou ont un taux de cholestérol élevé, s'ils ont des antécédents familiaux des précédentes maladies, s'ils ont plus de 45 ans, s'ils fument, s'ils sont obèses, s'ils n'ont pas fait d'exercices réguliers au cours de l'année précédente ou s'ils prennent des médicaments. Si vous avez des étourdissements ou des faiblesses, arrêtez les exercices immédiatement.*

- Do not allow children, or people unfamiliar with the operation of this equipment, on or near it. Do not leave children unsupervised around the equipment.
- Make sure all users wear proper exercise clothing and shoes for their workouts and avoid loose or dangling clothing. Users should not wear shoes with heels or leather soles, and they should check the soles of their shoes to remove any dirt and embedded stones. They should also tie long hair back.
- Never leave the equipment unattended when it is plugged in. Unplug the equipment from its power source when it is not in use, before cleaning it, and before providing authorized service.

Note: The optional power adapter is considered a power source for self-powered equipment.

- Use the power adapter provided with the equipment. Plug the power adapter into an appropriate, grounded power outlet as marked on the equipment.

- Care should be taken when mounting or dismounting the equipment.
- For Treadmills: Do not use typing or web surfing features while walking at speeds that exceed a **slow and relaxed leisurely pace**. Always stabilize yourself by holding a stationary handle bar while using typing or web surfing features.
- For AMT and EFX: Always stabilize yourself by holding a stationary handle bar while using typing or web surfing features.
- Read, understand, and test the emergency stop procedures before use.
- Keep the power cord or optional power adapter and plug away from heated surfaces.
- Route power cables so that they are not walked on, pinched, or damaged by items placed upon or against them, including the equipment itself.
- Ensure the equipment has adequate ventilation. Do not place anything on top of or over the equipment. Do not use on a cushioned surface that could block the ventilation opening.
- Assemble and operate the equipment on a solid, level surface.

- **SPACING**—The below minimum spacing recommendations are based on a combination of the ASTM (U.S.) voluntary standards and EN (European) regulations as of October 1, 2012, for access, passage around, and emergency dismount:
 - **Treadmills**—a minimum of 0.5 m (19.7 in.) on each side of the treadmill and 2 m (78 in.) behind the machine.
 - **Cardio equipment other than treadmills**—a minimum of 0.5 m (19.7 in.) on at least one side, and .5 m (19.7 in.) behind or in front the machine.

Careful consideration should be given to the requirements of the Americans with Disabilities Act (ADA), US Code 28 CFR (see Section 305). ASTM

standards are voluntary and may not reflect current industry standards. The actual area for access, passage around, and emergency dismount is the responsibility of the facility. The facility should consider the total space requirements for training on each unit, voluntary and industry standards, and any local, state, and federal regulations. Standards and regulations are subject to change at any time.

Important: *These spacing recommendations should be used when positioning equipment away from sources of heat, such as radiators, heat registers, and stoves. Avoid temperature extremes.*

- Keep equipment away from water and moisture. Avoid dropping anything on or spilling anything inside the equipment to prevent electric shock or damage to the electronics.
- When using the treadmill, always attach the safety clip to your clothing before beginning your workout. Failure to use the safety clip may pose a greater risk of injury in the event of a fall.
- Keep in mind that heart rate monitors are not medical devices. Various factors, including the user's movement, may affect the accuracy of the heart rate readings. The heart rate monitors are intended only as exercise aids in determining heart rate trends in general.
- Do not operate electrically powered equipment in damp or wet locations.
- Never operate this equipment if it has a damaged cord or plug, if it is not working properly, or if it has been dropped, damaged, or exposed to water. Call for service immediately if any of these conditions exist.

- Maintain the equipment to keep it in good working condition, as described in the *Maintenance* section of the owner's manual. Inspect the equipment for incorrect, worn, or loose components, and then correct, replace or tighten prior to use.
- If you plan to move the equipment, obtain help and use proper lifting techniques.
- Equipment Weight Restrictions: Do not use the treadmill if you weigh more than 500 pounds (225 kg). If you weigh more than 350 pounds (160 kg), do not run on the treadmill. For all other fitness equipment, the weight limit is 350 pounds (160 kg).
- Use the equipment only for its intended purpose as described in this manual. Do not use accessory attachments that are not recommended by Precor. Such attachments may cause injuries.
- Do not operate the equipment where aerosol (spray) products are being used or where oxygen is being administered.
- Do not use outdoors.
- Do not attempt to service the equipment yourself, except to follow the maintenance instructions in the owner's manual.
- Never drop or insert objects into any opening. Keep hands away from moving parts.
- Do not set anything on the stationary handrails, handlebars, control console, or covers. Place liquids, magazines, and books in the appropriate receptacles.
- Do not lean on or pull on the console at any time.



CAUTION: DO NOT remove the cover, or you may risk injury due to electric shock. Read the assembly and maintenance guide before operating. There are no user-serviceable parts inside. Contact Customer Support if the equipment needs servicing. For use with single phase AC power only.

Educating Users

Take time to educate users about the Important Safety Instructions found in both the *User Reference Manual* and *Product Owner's Manual*. Explain to your club or facility patrons that they should observe the following precautions:

- Hold onto a stationary handrail or handlebar while assuming the starting position on the equipment.
- Face the console at all times.
- Hold on to a stationary handrail or handlebar with one hand whenever you operate the console keys with the other hand.

Hazardous Materials and Proper Disposal

The batteries within self-powered equipment contain materials that are considered hazardous to the environment. Federal law requires proper disposal of these batteries.

If you plan to dispose of your equipment, contact Precor Commercial Products Customer Support for information regarding battery removal. Refer to *Obtaining Service*.

Product Recycling and Disposal

This equipment must be recycled or discarded according to applicable local and national regulations.

Product labels, in accordance with European Directive 2002/96/EC concerning waste electrical and electronic equipment (WEEE), determine the framework for the return and recycling of used equipment as applicable throughout the European Union. The WEEE label indicates that the product is not to be thrown away, but rather reclaimed upon end of life per this Directive.

In accordance with the European WEEE Directive, electrical and electronic equipment (EEE) is to be collected separately and to be reused, recycled, or recovered at end of life. Users of EEE with the WEEE label per Annex IV of the WEEE Directive must not dispose of end of life EEE as unsorted municipal waste, but use the collection framework available to customers for the return, recycling, and recovery of WEEE. Customer participation is important to minimize any potential effects of EEE on the environment and human health due to the potential presence of hazardous substances in EEE. For proper collection and treatment, refer to *Obtaining Service*.

Regulatory Notices for the RFID Module

When equipped with a control console as described in this document, this equipment may include a radio-frequency identification (RFID) module. The RFID module has been certified to operate at temperatures between -20°C and 85°C (-4°F and 185°F).

Radio Frequency Interference (RFI)

The RFID module conforms to the following national standards defining acceptable limits for radio frequency interference (RFI).

Federal Communications Commission, Part 15

This equipment has been tested and found to comply with the limits for a Class A digital device, pursuant to Part 15 of the FCC Rules. These limits are designed to provide reasonable protection against harmful interference in a commercial installation. The equipment generates, uses, and can radiate radio frequency energy and, if not installed and used in accordance with the owner's manual instructions, can cause harmful interference to radio communications.

Operation is subject to the following two conditions: (1) this device may not cause harmful interference, and (2) this device must accept any interference received, including interference that may cause undesired operation.

WARNING Per FCC rules, changes or modifications not expressly approved by the manufacturer could void the user's authority to operate the equipment.

Industry Canada

This device complies with RSS-210:2007 of the Spectrum Management & Telecommunications Radio Standards Specification. Operation is subject to the following two conditions: (1) this device may not cause harmful interference, and (2) this device must accept any interference received, including interference that may cause undesired operation.

This Class A digital apparatus complies with Canadian ICES-003.

Cet appareil numérique de la classe A est conforme à la norme NMB-003 du Canada.

ATTENTION: Haute Tension
Débranchez avant de réparer

European Applications

CE compliance is claimed to the following directives:

- 1999/5/EC R&TTE Directive
- 2006/95/EC LVD Directive
- 2002/95/EC RoHS Directive

Directive compliance has been verified to the following standards:

- EN 55022
- EN 300 330-1 V1.5.1
- EN 300 330-2 V1.3.1
- EN 301 489-3 V1.4.1
- EN 301 489-1 V1.8.1
- EN 60950-1

Regulatory Notices for Cardiovascular Exercise Equipment

The regulatory information in this section applies to the exercise equipment and its control console.

Safety Approvals for Cardiovascular Equipment

Precor equipment has been tested and found to comply with the following applicable safety standards.

Cardiovascular Type Equipment:

- CAN/CSA, IEC, EN 60335-1 (Household and similar electrical appliances - Safety)
- EN 957 (Stationary training equipment, class S/B compliant equipment)

PVS and P80 Regulatory Notice

This Precor equipment has been tested and found to comply with the following applicable safety standards.

- CAN/CSA, UL, IEC, EN 60065 (Audio, video and similar electronic apparatus - Safety)

Radio Frequency Interference (RFI)

This Precor exercise equipment conforms to the following national standards defining acceptable limits for radio frequency interference (RFI).

Federal Communications Commission, Part 15

This equipment has been tested and found to comply with the limits for a Class A digital device, pursuant to Part 15 of the FCC Rules. These limits are designed to provide reasonable protection against harmful interference in a commercial installation. The equipment generates, uses, and can radiate radio frequency energy and, if not installed and used in accordance with the owner's manual instructions, may cause harmful interference to radio communications.

WARNING Per FCC rules, changes or modifications not expressly approved by Precor could void the user's authority to operate the equipment.

Industry Canada

This Class A digital apparatus complies with Canadian ICES-003.

Cet appareil numérique de la classe A est conforme à la norme NMB-003 du Canada.

ATTENTION: Haute Tension
Débranchez avant de réparer

European Applications

CE compliance is claimed to the following directives:

- 2004/108/EC EMC Directive
- 2006/95/EC LVD Directive
- 2002/95/EC RoHS Directive

Directive compliance has been verified to the following standards:

- EN 55022
- EN 55024
- EN 60335-1
- EN 60065 (P80 and PVS)

Electrical Recommendations: All Equipment Excluding Treadmills

Note: This is a recommendation only. NEC (National Electric Code) guidelines or local region electric codes must be followed.

For equipment fitted with a P80 console or Personal Viewing System (PVS) screen a separate power connection is required. For a 20 amp branch circuit up to 10 screens can be connected. If the branch circuit has any other devices plugged into the circuit, then the number of screens must be reduced by the wattage of the other devices.

Note: The typical splitter power cords that have IEC-320 C13 and C14 plugs have a recommended maximum capacity of five screens.

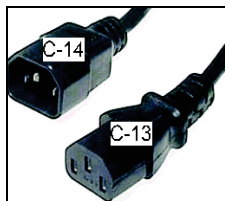

Figure 1: IEC-320 C13 and C14 plugs

Obtaining Service

Do not attempt to service the equipment except for maintenance tasks. If any items are missing, contact your dealer. For more information regarding customer support numbers or a list of Precor authorized service centers, visit the Precor web site at <http://www.precor.com>.

Obtaining Updated Documentation

Current Precor product documentation is available at **<http://www.precor.com/productmanuals>**. You may want to check in for updated information from time to time.

Table of Contents

Important Safety Instructions	3
Safety Precautions.....	4
Educating Users	8
Hazardous Materials and Proper Disposal.....	8
Product Recycling and Disposal	8
Regulatory Notices for the RFID Module	9
Regulatory Notices for Cardiovascular Exercise Equipment.....	11
Electrical Recommendations: All Equipment Excluding Treadmills	13
Obtaining Service.....	13
Obtaining Updated Documentation	14
Assembling the AMT	17
Hardware Kit (not to scale)	18
Required Tools.....	19
Unpacking the AMT	19
Adding the Side Arm Supports	20
Removing Access Covers	26
Threading the Console Cables	29
Replacing Access Covers.....	32
Positioning the Handlebars	34
Leveling the AMT	37
Breaking in the Equipment	39
Installing the Console	41
Threading the Cable Assembly (P80)	42
Connecting Cables (P80).....	44
Completing the Console Installation (P80).....	50
Threading the Cable Assembly (P30 and P10)	50
Connecting Cables (P30 and P10)	52
Completing the Console Installation (P30 and P10).....	55
Verifying That the Heart Rate Display Is Operational	56

Maintenance.....	57
Daily Cleaning	57
Daily Inspection	58
Cleaning the P80 Console and Display	59
Weekly Maintenance	60
Monthly Maintenance	60
Changing the Belt (Newer Model AMT Only)	61
Storing the Chest Strap.....	61
Moving the Equipment	61
Long-Term Storage.....	62
Self-Powered Features.....	63
Informational Displays Prior to Shutdown	64
Symptoms of a Low Battery	64
Using the Optional Power Adapter	65
The Optional Power Adapter Kit.....	65
Replacing the Battery	66
Commercial Cardiovascular Equipment Limited Warranty.....	67

Assembling the AMT

Important: The instructions in the following procedures are described from the perspective of a person standing **directly in front of the equipment** (that is, on the opposite side of the control console from a person using the equipment). These descriptions may not match the names of certain parts in the parts list, because such parts are named relative to the back of the equipment.

To prepare the AMT for assembly:

- Open the box and assemble the components in the sequence presented in this guide.
- Assemble and operate your equipment on a hard, level surface in the area intended for use.

Important: Do not grasp any plastic parts of the unit while lifting or moving the unit. The plastic parts are non-structural covers and are not capable of supporting the weight of the unit.

- Provide ample space around the unit.
- Assemble the equipment according to the guidelines in this manual to ensure you do not void the Precor Limited Warranty.

Important: Any damage caused during installation is not covered by the Precor Limited Warranty.

- Attach all fasteners and partially tighten them. Do not fully tighten fasteners until instructed to do so.

WARNING You will need assistance to assemble this unit. **DO NOT attempt assembly by yourself.**

Hardware Kit (not to scale)

The hardware kit shipped with this equipment contains the fasteners and other hardware components shown in the following table. Before you begin assembly, make sure that your hardware kit is complete. If not, please contact Precor Customer Support.

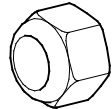
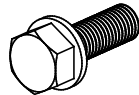
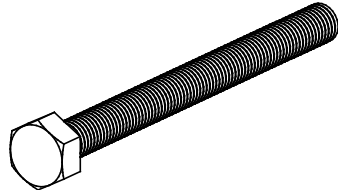
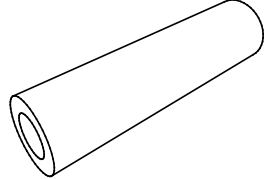
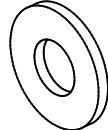
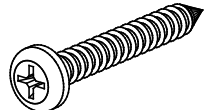
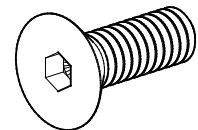
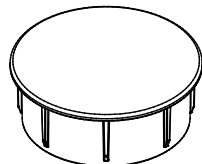
Fasteners	Quantity
	Nylon lock nuts ($\frac{5}{16}$ -inch) 6
	Hex head bolts ($\frac{5}{16}$ -inch x 1-inch) 4
	Hex head bolts ($\frac{5}{16}$ -inch x 3½-inch) 6
	Bolt sleeve ($\frac{5}{16}$ -inch) 2
	Flat washers ($\frac{5}{16}$ -inch) 6
	Self-tapping screw (#10 x 1¼) 6
	Flat head hex drive screws ($\frac{1}{4}$ -inch x $\frac{5}{8}$ -inch) 5
	End caps 2

Required Tools

- #2 Phillips screwdriver
- Rubber mallet
- SAE standard socket set
- Wire cutter
- Two #1 Phillips screwdrivers
- Torque wrench (calibrated in inch-pounds, and including $\frac{3}{16}$ -inch hex wrench bit)

Unpacking the AMT

DANGER Do not attempt to connect electrical power until all assembly procedures are complete and the console is properly installed.

CAUTION: Do not climb onto the AMT until directed to do so.

Follow these steps to remove the AMT base unit from its shipping container.

To unpack the AMT:

1. Remove the rear pedestal and set it aside.
2. Remove and discard the fastener securing the back of the center support to the shipping pallet.
3. Remove and discard the bolts and nuts securing the wooden supports to the side arms of the AMT.
4. Remove the fasteners securing the wooden supports to the shipping pallet, then discard the supports and the fasteners.

Important: In the following step, do not force the foam block placed around the center support. Doing so may damage the plastic cover on the center support. Instead, slide the foam block backward until you have removed it from the plastic cover, then lift it out of the way.

5. Cut and remove the plastic ties, bubble wrap, and foam blocks securing the unmounted parts inside the shipping container.

Adding the Side Arm Supports

In the next procedure you will need the following pieces of hardware:

- Two side arm supports
- Two inner side arm covers
- Two outer side arm covers
- Six #10 x 1¼-inch self-tapping screws
- Six 5/16-inch x 3½-inch hex head bolts
- Six 5/16-inch nylon lock nuts
- Six 5/16-inch flat washers
- Four 5/16-inch x 1-inch hex head machine screws

Important: *The side arm supports are shipped with foam blocks inserted in one end. These blocks are provided to prevent fasteners from falling into the supports. Do not remove the foam blocks or push them down into the supports.*

To add the side arm supports:

1. Place the upper end of the right-hand support against the right-hand side arm.
2. Insert two 5/16-inch x 1-inch hex head machine screws (with washers attached) into the two holes underneath the side arm support bracket and tighten partially.

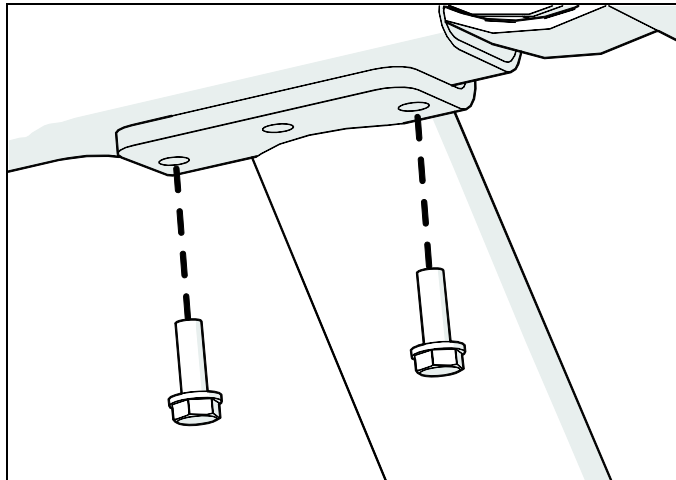

Figure 2: Machine screw attachment to install side arm support

- Slide one $\frac{5}{16}$ -inch flat washer and one $\frac{5}{16}$ -inch sleeve over one of the $\frac{5}{16}$ -inch x $3\frac{1}{2}$ -inch hex head bolts.

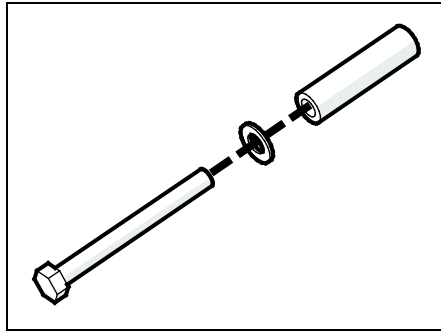

Figure 3: Adding the sleeve and washer

- Insert the $\frac{5}{16}$ -inch x $3\frac{1}{2}$ -inch hex head bolt, with the washer and sleeve, into the screw hole on the inside of the right-hand side arm. Attach a $\frac{5}{16}$ -inch nylon lock nut to the end of the bolt and tighten partially.

Important: Be sure to insert the bolt into the inward side of the side arm and apply the nut to the outward side, as shown in the following figure. If the bolt is inserted in the other direction, the side arm covers will not fit. Do not tighten fasteners completely until instructed to do so.

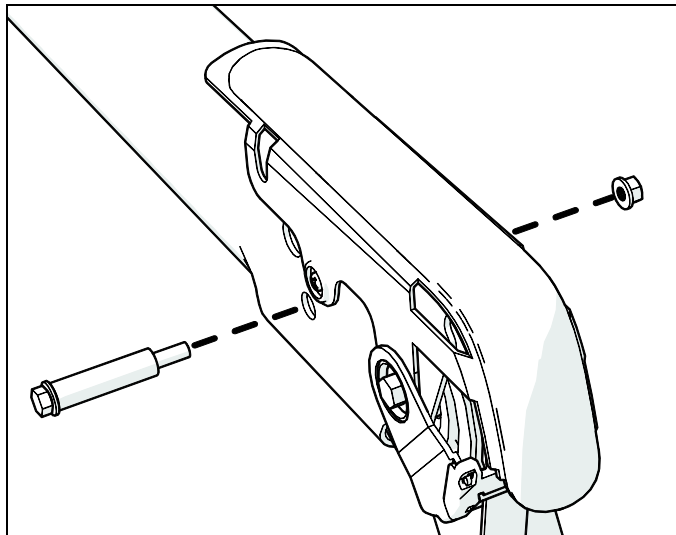

Figure 4: Bolt and sleeve attachment to install side arm support

- Repeat steps 1 through 4 to attach the left-hand side arm support to the left side arm.

6. Place the flanges of the two side arm supports against the sets of screw holes on the center support. Insert a screwdriver through the middle holes in both flanges and the center support to keep the screw holes aligned.

Note: Use narrow screwdrivers, such as #1 Phillips screwdrivers, for this step. If necessary, use them to help pull the side arm supports into place against the center support.

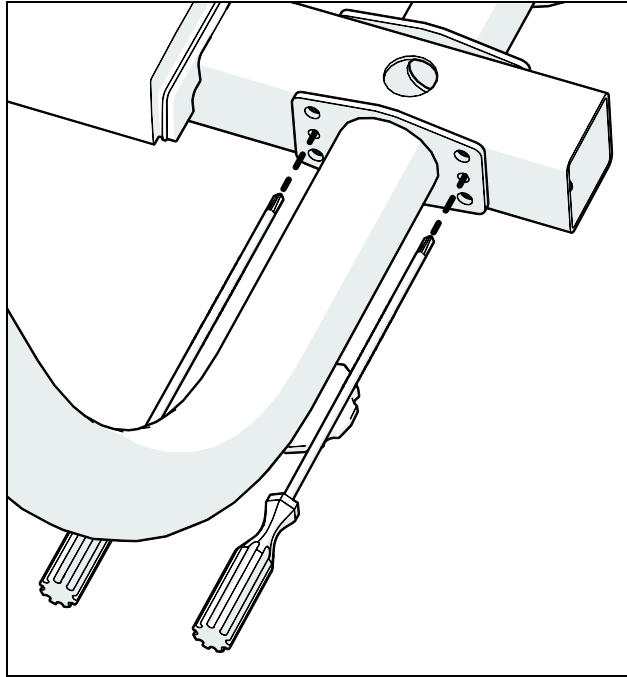

Figure 5: Lower side arm support alignment

7. Slide a $\frac{5}{16}$ -inch flat washer over each of the four $\frac{5}{16}$ -inch x $3\frac{1}{2}$ -inch hex head bolts.

8. On the opposite side of the center support from the handles of the screwdrivers, insert the four $\frac{5}{16}$ -inch x $3\frac{1}{2}$ -inch hex head bolts. Attach a $\frac{5}{16}$ -inch nylon lock nut to each bolt. Partially tighten the fasteners, then remove the screwdrivers.

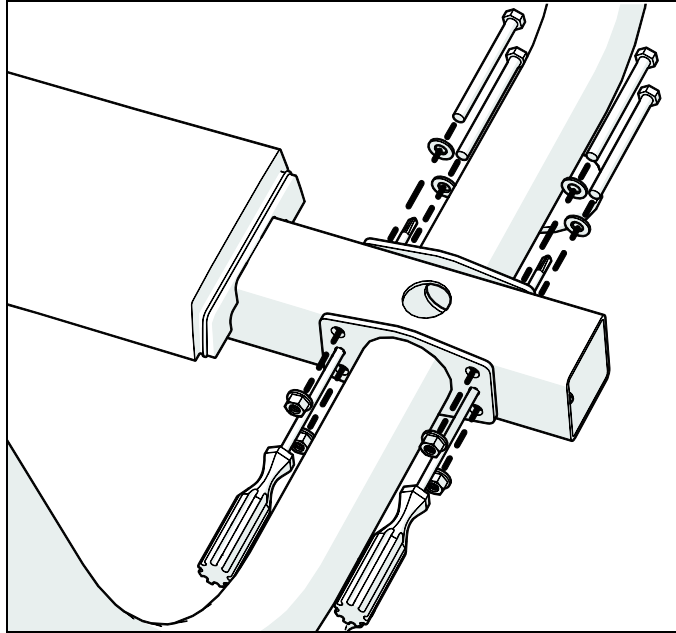

Figure 6: Lower side arm attachment

9. Adjust the side arm supports as needed, then tighten all of its fasteners to 160 inch-pounds of torque.
10. Extend the adjustable feet on the side arm supports until they touch the floor, then remove the spacer block from under the back end of the AMT.

Note: If necessary, use a $\frac{9}{16}$ -inch open-ended wrench to loosen the jam nuts on the adjustable feet.

11. Remove the two #10 x $\frac{3}{4}$ -inch Phillips-head screws securing the upper back corner of the inner plastic molding to the end of the right side arm.

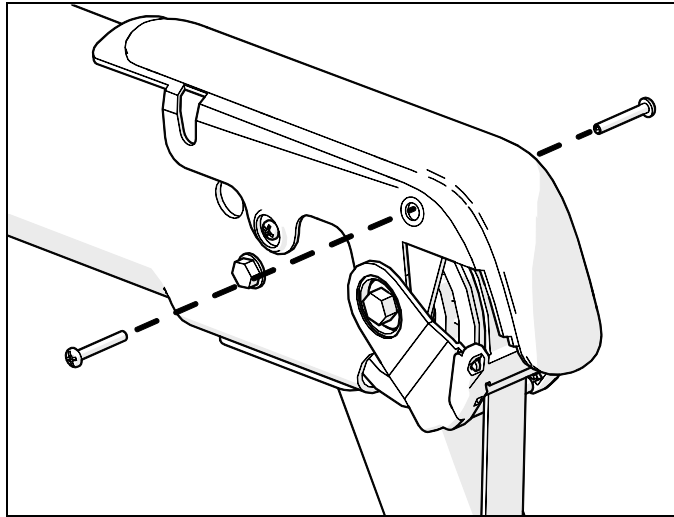

Figure 7: Removal of screws from inner plastic molding

12. Fit the right-hand inner and outer side arm covers to the right side arm. Insert three #10 x $\frac{1}{4}$ -inch self-tapping screws and the two #10 x $\frac{3}{4}$ -inch screws you removed in the previous step, then tighten all of the screws completely using a #2 Phillips screwdriver.

Note: Tighten the screws to between 8 and 12 inch-pounds. Alternatively, tighten the screws until the two side arm covers are in full contact, then turn the screws an additional quarter turn.

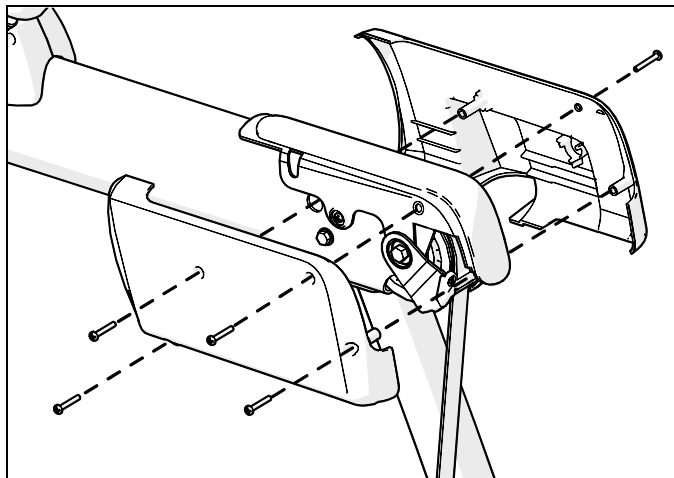

Figure 8: Side arm cover attachment

13. Repeat the previous two steps for the left side arm.

After the side arm supports are secured, move the AMT off of its shipping pallet to the location where you intend it to be used.

CAUTION: Do not move the AMT off of its shipping pallet without assistance. Do not apply any weight or other force to the side arms of the AMT until the side arm supports have been installed. To avoid unnecessary movement of the foot plates, do not position the handlebars until instructed to do so.

To move the AMT from the pallet to its intended location:

1. Remove and discard the two fasteners securing the front frame tube of the AMT to the shipping pallet, as shown in the following figure.

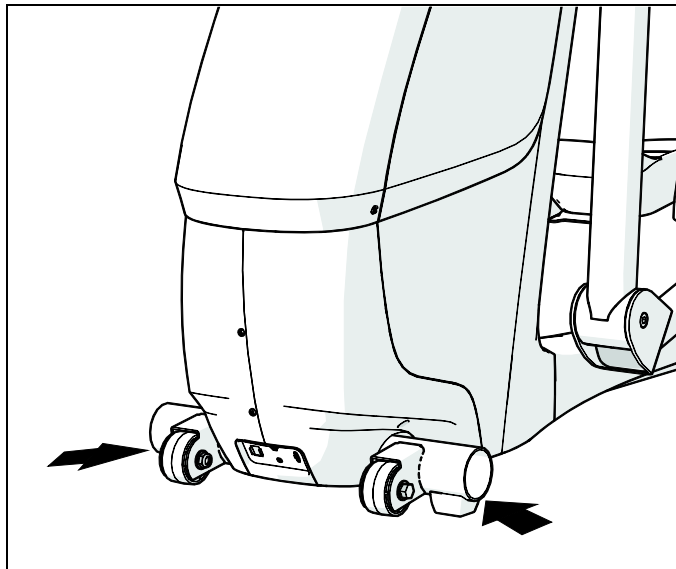

Figure 9: Front pallet anchor locations

2. Lift the back end of the center support and roll the AMT forward while your assistant stabilizes its front end and guides it off the shipping pallet onto the floor.
3. Move the AMT ahead to its intended location.
4. Insert the end caps into the front frame tube. If necessary, use a rubber mallet to tap them into place.

Removing Access Covers

Removing the front and side access covers provides sufficient space to install the console cables.

Note: If you are installing a P10 or P30 console without a Personal Video System (PVS) or other accessory cap, you do not need to remove any access covers. Continue with the next section of the manual.

Important: Before continuing with the following procedure, be sure to remove any ties or other materials that hold the side arms in place before the supports are installed. Set aside all covers and fasteners that you remove in this procedure for later use.

To remove the access covers:

1. Lift the moisture seal upward and remove it from the center support.

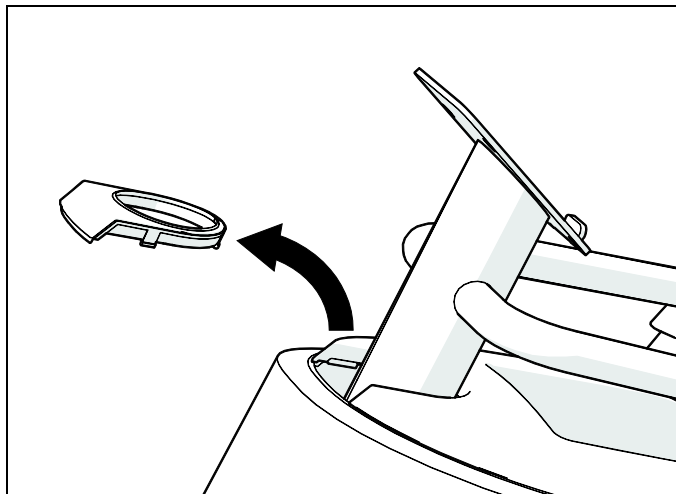

Figure 10: Moisture seal removal

2. Extend a finger through the moisture seal opening and under the front edge of the top cover on one side. While pressing upward on the top cover, use the heel of your hand to tap gently below its front edge and release it. Repeat this step to release the other side of the top cover.

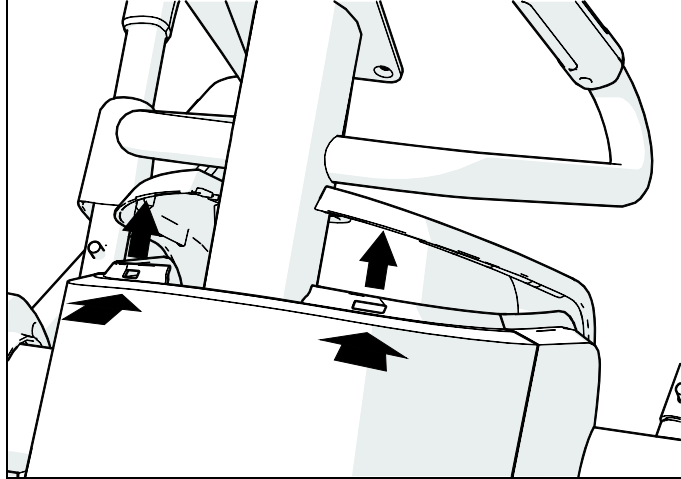

Figure 11: Top cover removal

3. While holding the front edge of the top cover up, use the heel of your other hand to tap gently just below the cover's back edge. Lift the cover up and out of the way.

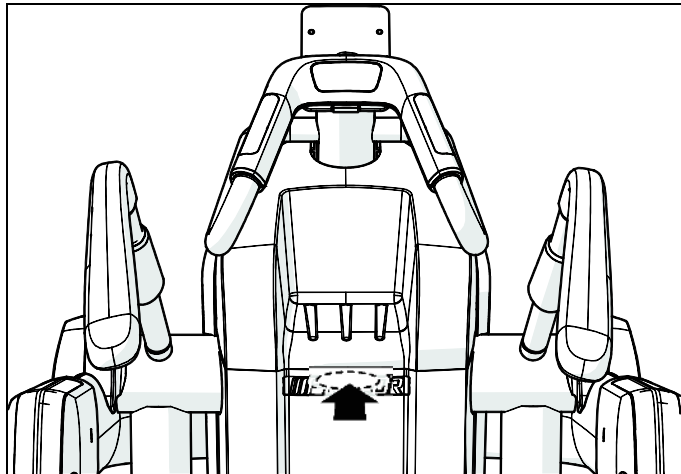

Figure 12: Releasing the back of the top cover

4. Remove the two #10 x $\frac{3}{4}$ -inch screws at the bottom corners of the front cover assembly.

5. Gently press in on each of the side covers, just behind the front edge and about 8½ inches from the bottom, while pulling the front cover assembly forward to disengage it.

Note: Each side cover has a small triangular mark to show you where to press.

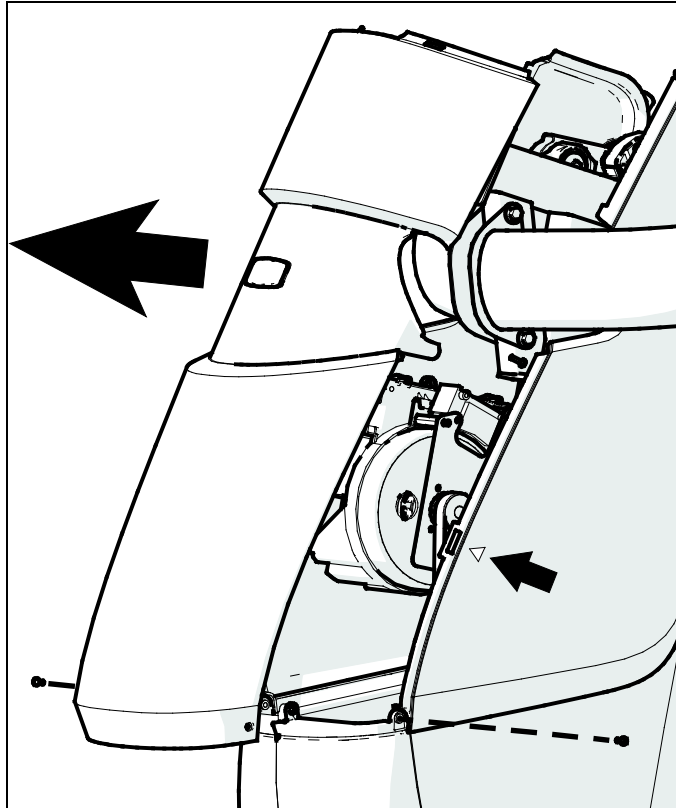

Figure 13: Front cover assembly removal

6. Move the front cover assembly forward and slightly upward to remove it.

Threading the Console Cables

Before you begin this procedure, make sure that you have retrieved the following parts from the console package:

- Ethernet (CAT 5) coupler and cable (models with P80 consoles only)
- Television coupler and cable (models with P80 consoles or Personal Video Systems only)
- Console power cable (models with P80 consoles or Personal Video Systems only)

Important: Be absolutely certain that all cables pass through all of the cable clips. Do **not** allow any of the cables to hang near any moving parts.

To thread the console cables:

Important: If you are installing console power and television cables in the following step, pass the console power cable through the opening first, followed by the television cable. Pass the remaining cables through in order of connector size.

1. Pass the ends of all cables through the opening in the top of the cable channel above the jack plate, then slide the cables into the guides in the channel.

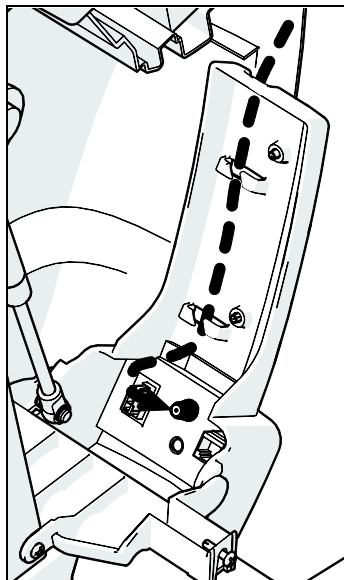

Figure 14: Cable routing through the lower cable channel

2. Remove the nut from the outward end of the television cable coupler.

3. Insert the connectors into the jack plate at the lower front of the AMT, as shown in the following figure and table.

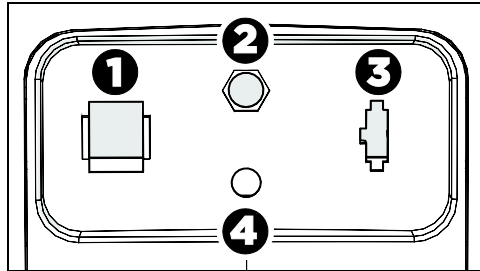

Figure 15: Jack plate layout

Table 1. AMT connector locations

Position	Connector
1	Ethernet coupler (P80 console only)
2	Television cable coupler (P80 console only)
3	Console power cable (P80 console only)
4	External power connector for base unit (optional)

Important: In the following step, do not overtighten the connector. Finger-tighten it until it is snug, then use the wrench to tighten it only slightly (8 to 9 inch-pounds).

4. Replace the nut that you removed from the television cable coupler in step 2, then tighten it slightly using a $\frac{7}{16}$ -inch open-end wrench.
5. Plug the Ethernet cable into the inside jack on the Ethernet coupler.
6. Connect the television cable to the inside end of the television cable coupler. Tighten the connector slightly using a $\frac{7}{16}$ -inch open-end wrench.

7. Route the cables through the three clips next to the front flywheel, then through the topmost cable clip on the main frame, and finally up to the center column.

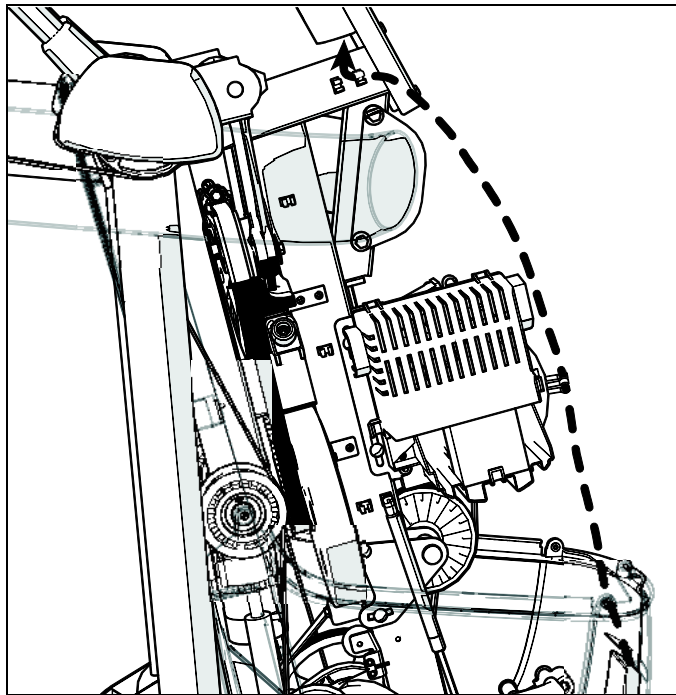

Figure 16: Cable routing along the frame to the center column

8. Remove the tie from the base unit data cable, then group that cable with the others.
9. Thread the cables upward through the center column and out through the center opening in the console mount, making sure that the heart rate sensor cable extends out of the opening as well.

Important: Store excess cable inside the center column. Do **not** allow cables to hang loosely inside the body of the AMT.

Replacing Access Covers

For this procedure, you will need the covers you removed earlier, as well as the fasteners you removed with them.

To replace the access covers:

1. Guide the arm openings in the front cover around the arms of the AMT, taking care that the tabs at the bottom corners of both openings are inside the two side covers, then guide the front cover into place until the latches on the side covers click into place.

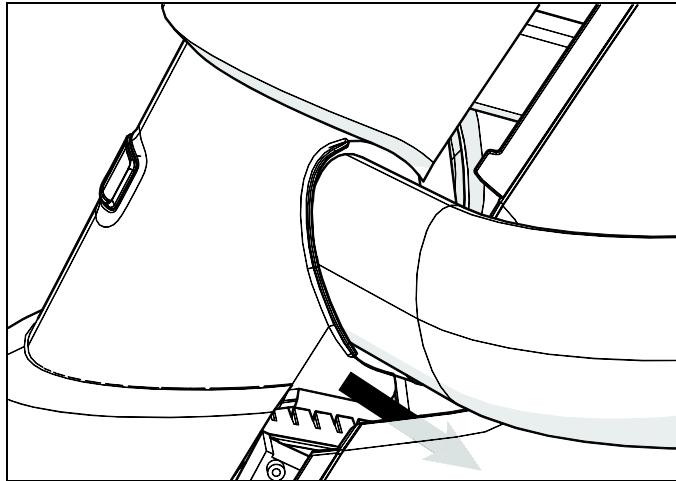

Figure 17: Front cover positioning

2. Reattach the two #10 x $\frac{3}{4}$ -inch screws at the bottom corners of the front cover. Tighten the screws completely.
Important: *In the following step, do not apply excessive force to seat the cover.*
3. Position the rear edge of the top cover so that the clips on the top and back covers are engaged securely.
4. Gently snap the front edge of the top cover into place, using the heel of your hand if necessary.

5. Wrap the moisture seal around the center column below the heart rate sensor grips, then fit it into the top cover. Make sure that the surfaces and edges of the moisture seal are flush with those on the top cover.

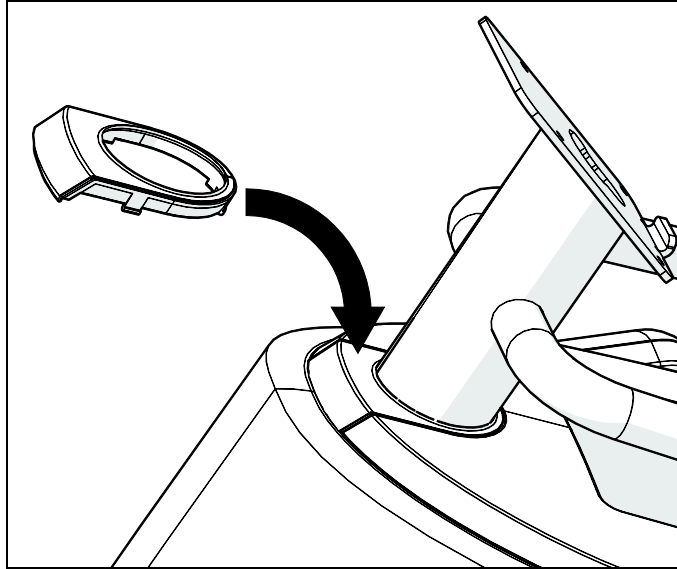

Figure 18: Moisture seal positioning

Positioning the Handlebars

To avoid damage in shipment, the ATM is packed with its handlebars reversed. Two $\frac{3}{8}$ -inch x $1\frac{1}{4}$ -inch set screws are loosely threaded into the screw holes on each handlebar. The plastic boots that will cover the screw holes are positioned just above them on the handlebars.

To position the handlebars for use:

1. Remove the two set screws from one handlebar.

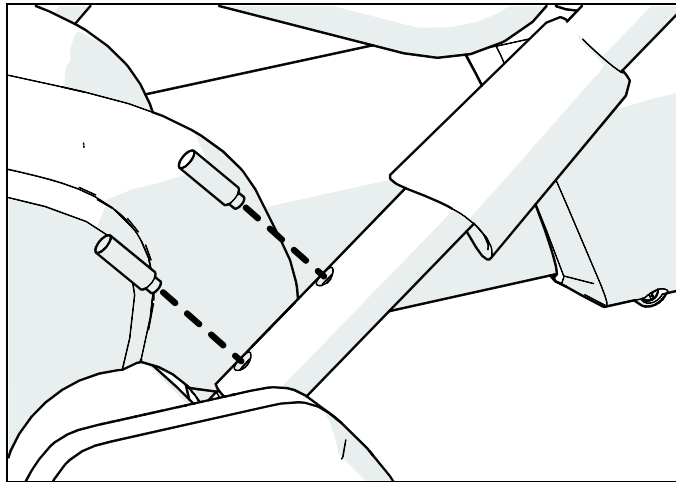

Figure 19: Handlebar set screw removal

2. Rotate the handlebar exactly one half turn (180°).
Note: When the handlebar is positioned correctly, it bends slightly outward. The screw holes in the handlebar should also line up with those on the AMT.

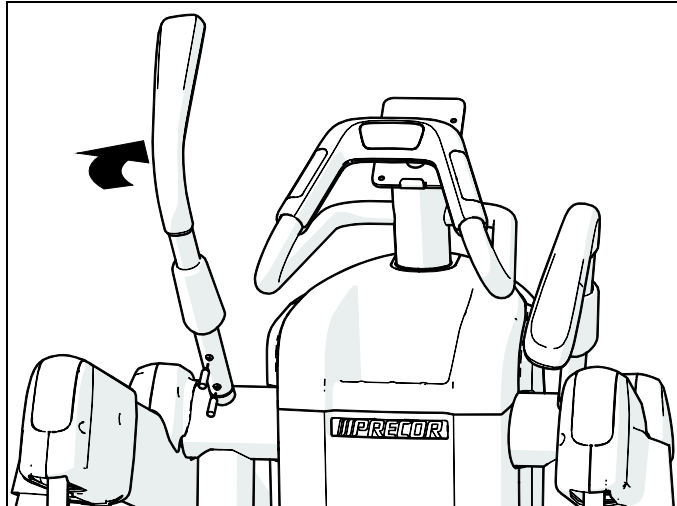

Figure 20: Handlebar positioning steps

3. Reinsert the two set screws. Leave the screws partially tightened until you have adjusted both handlebars.
4. Repeat steps 1 through 3 to position the other handlebar.

5. Adjust the positions of both handlebars outward as much as possible. Both handlebars should be at equal angles to the body of the AMT and angled slightly outward, as shown in the following figure.

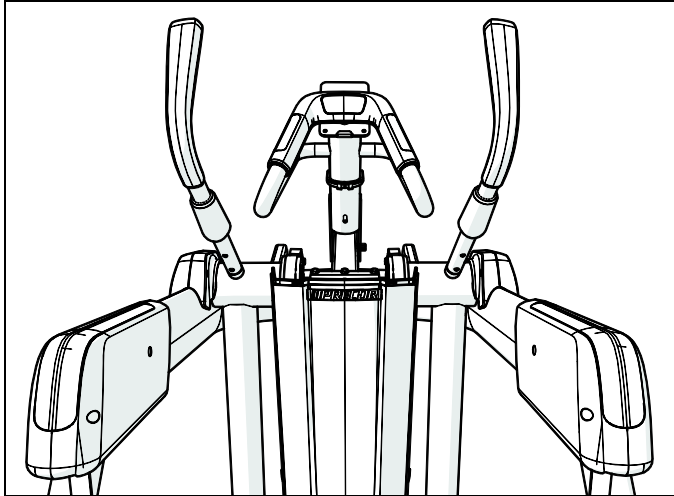

Figure 21: View of handlebar placement

6. Rotate one of the plastic boots so that it aligns with the surface below it, then press the boot downward to secure it in place. Repeat this step to position the other plastic boot.

Leveling the AMT

It is important that you level and stabilize the AMT properly every time you move it.

CAUTION: To eliminate movement, make sure the adjustable feet are in contact with the floor. Also, make sure that the unit sits on a flat surface. Adjusting the feet of the unit cannot compensate for extremely uneven surfaces.

To level the AMT:

1. Gently rock the AMT while standing on one of its foot plates and grabbing the opposite handlebar. First stand on the left foot plate and grab the right handlebar to rock the AMT, then repeat the step while standing on the right foot plate and holding the left handlebar. If there is any movement, ask your assistant to tip the unit on its side while you locate the adjustable feet.

Note: Alternatively, place the angled end of a 12" pry bar against the underside of the back frame tube at its end, then press the straight end of the pry bar against the floor to lift the back of the AMT a few inches.

2. Using a $\frac{9}{16}$ -inch open-ended wrench, move the jam nuts away from the side arm supports and toward the adjustable feet.

3. Reposition the adjustable feet as needed.

If you want to ...

Then turn the adjustable feet ...

Raise the front end of the AMT

Counterclockwise

Lower the front end of the AMT

Clockwise

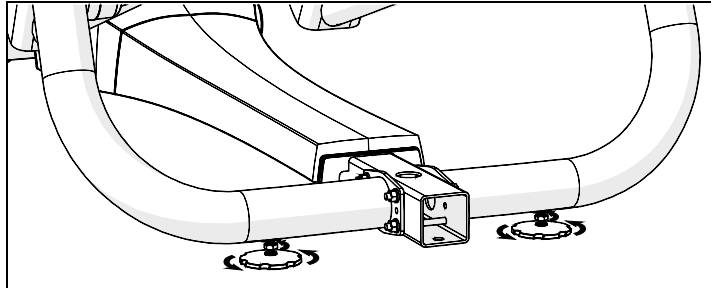

Figure 22: Location of adjustable feet and jam nuts

Important: To allow the rear pedestal to fit properly, the adjustable feet must extend at least 2" (5 cm) below the side arm supports. Extending the feet before you remove the spacer block, as described in the section Adding the Side Arm Supports earlier in this chapter, ensures that they are positioned correctly.

4. When you are finished positioning the adjustable feet, place the unit on the floor. Try rocking it again, as described in step 1, to verify that it is level.
5. Using the $\frac{9}{16}$ -inch open-ended wrench, move the jam nuts upward until they contact the side arm supports. Tighten the jam nuts completely.
6. Align the rear pedestal over the back frame tube and the side arm covers, then press it gently into place.

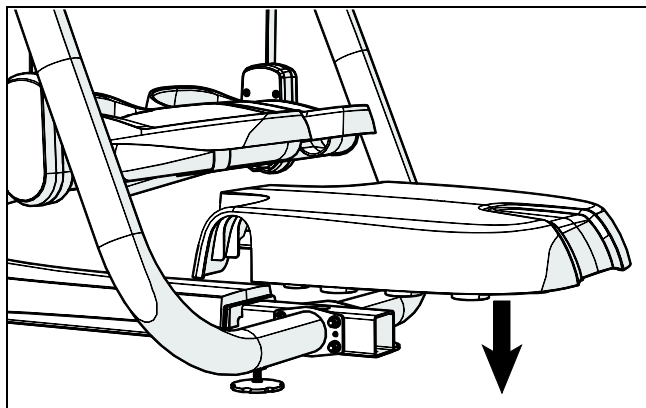

Figure 23: Rear pedestal attachment

Breaking in the Equipment

Precor equipment does not require an actual break-in period. However, moving components such as belts, gears, and bearings can settle while the equipment is being stored or shipped. This can cause the equipment to operate with a small amount of roughness or noise when it starts up for the first time.

The equipment usually returns to smooth operation after a day or two of normal use. If it does not, contact your dealer for assistance. For more information, refer to *Obtaining Service*.

Installing the Console

To make installation easier, all Precor Experience Series consoles use the same mounting hardware and connector locations whenever possible. The installation sequence for any of them is as follows:

- Threading the cable assembly
- Connecting cables
- Completing the installation (tightening the mounting screws and attaching the back cover)

The following sections describe how to perform these tasks.

Threading the Cable Assembly (P80)

Earlier in the installation, you threaded the necessary cables through the frame of the base unit and out the passthrough opening in the console mount. As you line up the back plate on the console with the console mount, you must make sure that the cable assembly passes correctly through the openings in both components.

Important: Before you begin the following procedure, remove the rear cover from the control console. To remove the cover, use your fingernails to pry the lower edge loose, then swing the cover up and out as shown in the following illustration.

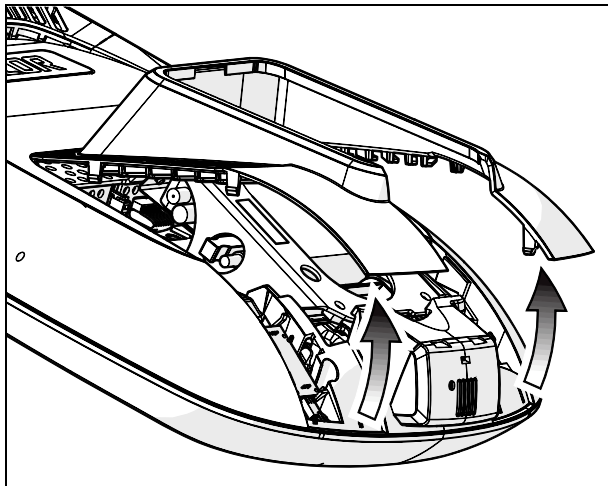

Figure 24: Removing the access cover from the P80 console

To thread the cable assembly:

1. Make sure that as much of each cable as possible passes through the opening in the middle of the console mount on the base unit.
2. Position the console over the console mount.

3. Rest the console on the console mount so that the notch on the bottom of the console's back plate rests on the rectangular hook at the bottom of the console mount, as shown in the following figure.

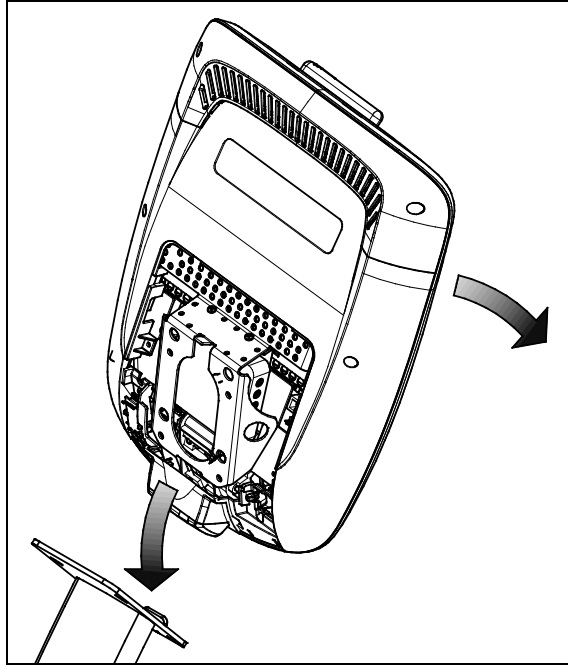

Figure 25: Console positioning on base unit

4. Tilt the console forward until it stops. Use one hand to steady the console in this position, or ask your assistant to do so.

Connecting Cables (P80)

After the console has been seated, separate the individual cables out of the end of the cable assembly and attach them to the appropriate circuit connectors inside the console. Refer to the following diagram and table to identify the cables and connectors.

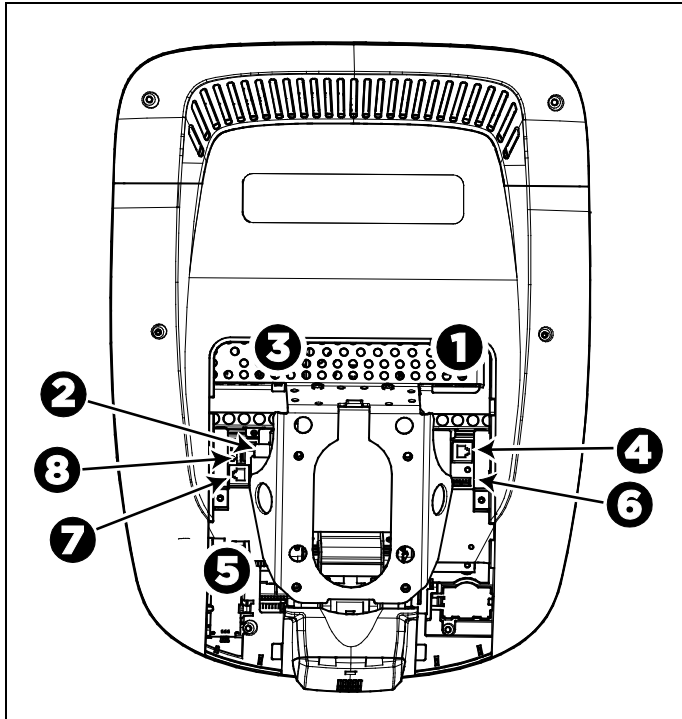

Figure 26: Cable connections, P80 console

Table 2. P80 internal cable connections

Cable	Connector Type	Circuit Connector Location
Ethernet (LAN)	Eight-contact modular, on round black cable	1
TV in	F-type coaxial	2
Power	Two-contact plug, polarized and latched	3
Data from base unit	Eight-contact modular, on flat gray cable	4
Heart rate sensors	Four-contact strip, keyed	5
Safety key (treadmills only)	Six-contact strip, keyed	6
CSAFE	Eight-contact modular, on flat gray cable	7
Automatic stop sensor (treadmills only)	Vertical four-contact strip, keyed	8

To simplify installation and maintenance, route and connect cables 1 through 5 according to the following instructions.

Note: In the illustrations in this section, some cables are omitted for the sake of clarity.

Connecting the Television Cable

The console's television tuner is mounted inside the console's back plate. The tuner includes a short cable adapter that allows the television cable to be connected outside the back plate.

To connect the television cable:

1. Pull the cable out through the lower right corner of the back plate.
2. Route the cable counterclockwise around the outside of the back plate.

Important: In the following step, install the cable using a torque wrench and torque not to exceed 8 lb-in. If a torque wrench is not available, install the coaxial cable using a plain wrench and tighten to "snug + ¼ turn." You may also use a wrench on the internal nut to help tighten the connection.

3. Attach the connector on the cable to the connector on the tuner cable and tighten the two connectors securely using two $\frac{7}{16}$ -inch open-end wrenches. Position both connectors above the upper right corner of the back plate.
4. Use a plastic tie to secure the connectors to the top of the back plate. Pass the tie through the two small holes near the upper right corner of the back plate, then wrap it around the connectors and tighten it securely. Cut off and remove the protruding end of the tie.

The following illustration shows how the cable is positioned once it is installed.

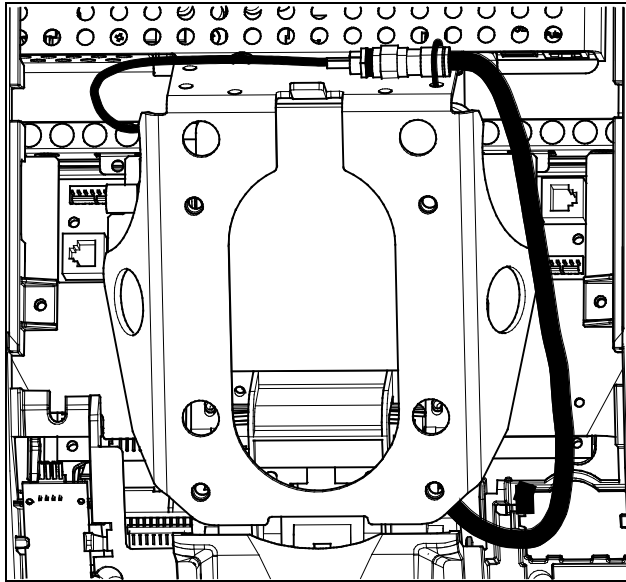

Figure 27: Connecting the television cable

Connecting the Ethernet and Base Unit Data Cables

Both the Ethernet and base unit data cables pass through the cutaway opening at the upper right corner of the back plate and connect to nearby modular jacks in the console. Because of this, it is important to exercise caution when connecting the cables. The black Ethernet cable connects to a jack just underneath the perforated metal bracket at the very top of the opening in the console. The gray base unit data cable connects to a lower jack closer to the back plate.

Refer to the following illustration for the correct position of both cables.

CAUTION: If you connect the base unit data cable to the wrong jack, the equipment will not function.

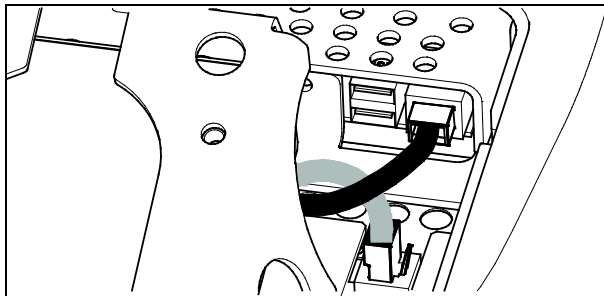

Figure 28: Connecting the Ethernet and base unit data cables

Connecting the Heart Rate Sensor Cable

The heart rate sensor cable passes through the cutaway opening at the upper left corner of the back plate, then down to the small circuit board at the lower left of the console. The following illustration shows how the cable should look once it is installed.

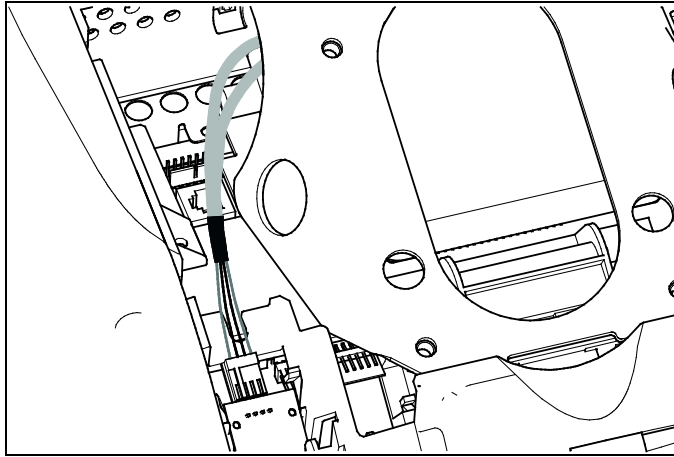

Figure 29: Connecting the heart rate cable

Connecting the Power Cable

Route the power cable through the cutaway opening at the upper left corner of the back plate. In the nearby opening within the steel console framework, locate the socket that matches the power cable plug and connect the power cable to it.

Note: Be sure that the latch on the plug clicks into place on the socket.

The following illustration shows how the cable should look once it is installed.

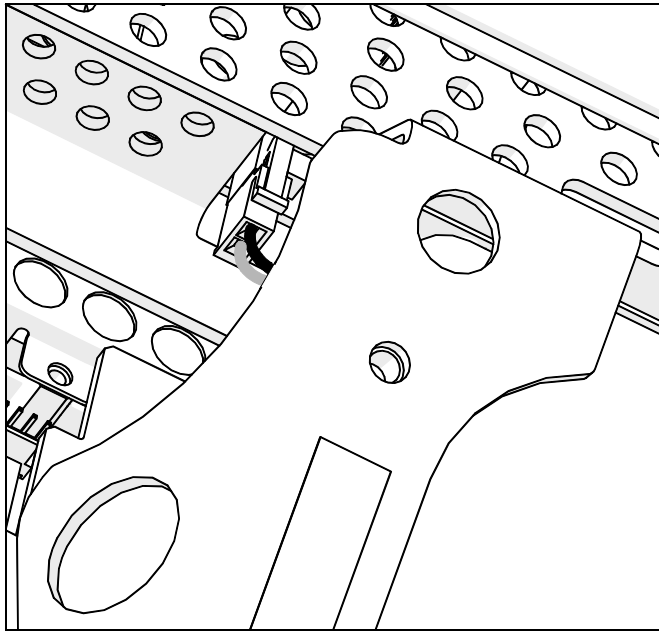

Figure 30: Connecting the power cable

Completing the Console Installation (P80)

Before you complete the final installation steps, double-check the connections you have made. Make sure that all cables are fully and securely connected, and that any unneeded cables are tied back properly.

To complete the installation:

1. Feed extra cable back into the neck tube.
2. Tilt the control console backward (toward yourself) until the tab on the top edge of its back plate slides along the top edge of the console mount and the screw holes align properly.
3. Insert the four $\frac{5}{8}$ -inch flat head screws through the holes in the console mount and thread them into the holes in the back plate on the console. Partially tighten the screws using a $\frac{5}{32}$ -inch hex wrench.
4. Line up the two small tabs at the top of the console's back cover with the slots at the top of the opening in the console case. Insert the tabs into the slots.
5. Insert the remaining tabs on the back cover with the corresponding slots on the console case.
6. Press gently on the edges of the back cover to snap it into place.

Threading the Cable Assembly (P30 and P10)

Earlier in the installation, you threaded the necessary cables through the frame of the base unit and out the passthrough opening in the console mount. As you line up the back plate on the console with the console mount, you must make sure that the cable assembly passes correctly through the openings in both components.

Important: Before you begin the following procedure, remove the rear cover from the control console. Set the cover and its mounting hardware aside for later use.

To thread the cable assembly:

1. Make sure that as much of each cable as possible passes through the opening in the middle of the console mount on the base unit.
2. Position the console over the console mount.

3. Rest the console on the console mount so that the notch on the bottom of the console's back plate rests on the rectangular hook at the bottom of the console mount, as shown in the following figure.

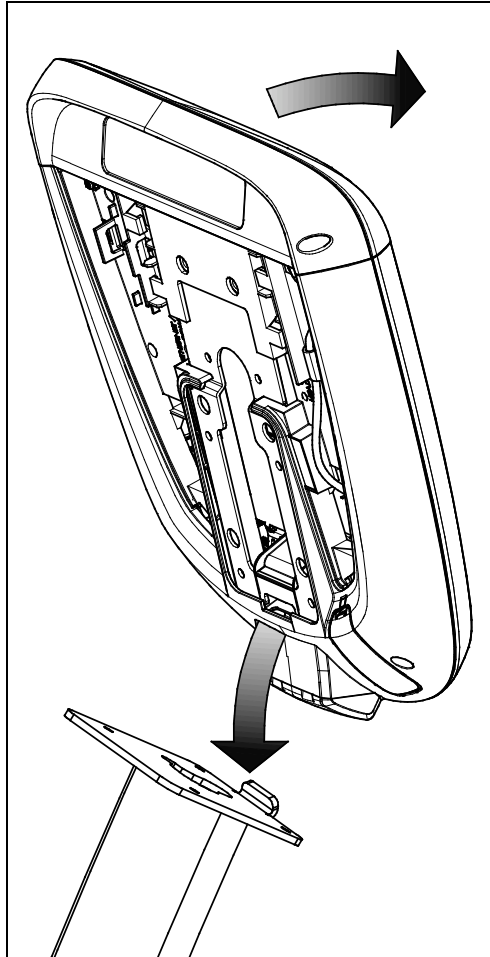

Figure 31: Console positioning on base unit

4. Tilt the console forward until it stops. Use one hand to steady the console in this position, or ask your assistant to do so.

5. Pull all cables upward and forward until you can drape them over the top of the console's back plate.

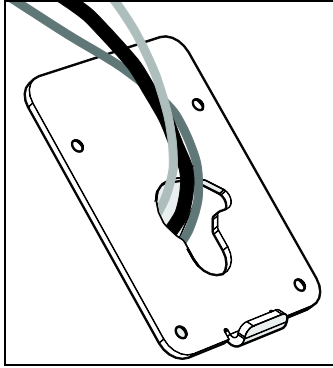

Figure 32: Cable positioning

Connecting Cables (P30 and P10)

Important: Pass all cables through the semicircular opening just above the console mount, as shown in the following figure. **Do not** attempt to route any cables through other openings or through the steel channel above the mount.

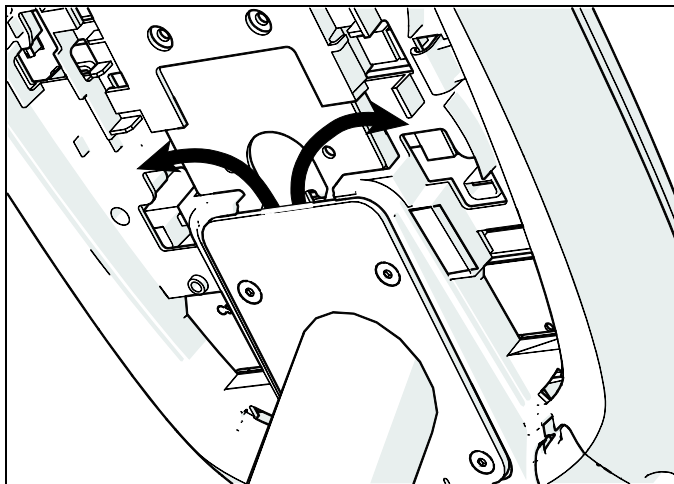

Figure 33: Cable routing from the mount into the console

After the console has been seated, separate the individual cables out of the end of the cable assembly and attach them to the appropriate circuit connectors inside the console. Refer to the following diagram and table to identify the cables and connectors.

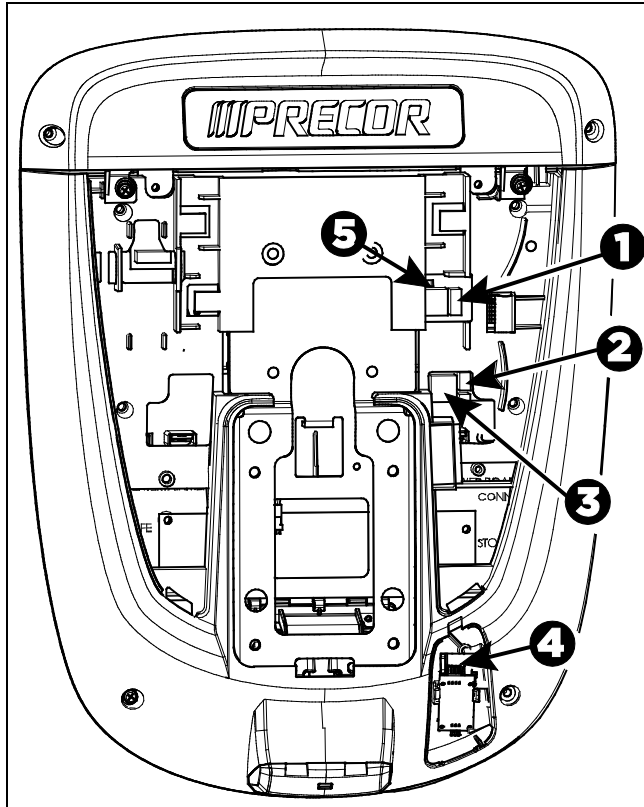

Figure 34: Cable connections, P30 and P10 consoles

Table 3. P30 and P10 internal cable connections

Cable	Connector Type	Circuit Connector Location
Safety key (treadmills only)	Six-contact strip, keyed	1
Automatic stop sensor (treadmills only)	Four-contact strip, keyed	2
Data from base unit	Eight-contact modular, on flat gray cable	3
Heart rate sensors	Four-contact strip, keyed	4
CSAFE	Eight-contact modular, on flat gray cable	5

Completing the Console Installation (P30 and P10)

Before you complete the final installation steps, double-check the connections you have made. Make sure that all cables are fully and securely connected, and that any unneeded cables are tied back properly.

To complete the installation:

1. Feed extra cable back into the neck tube.
2. Tilt the control console backward (toward yourself) until the tab on the top edge of its back plate slides along the top edge of the console mount and the screw holes align properly.
3. Insert the four $\frac{5}{8}$ -inch flat head screws through the holes in the console mount and thread them into the holes in the back plate on the console. Partially tighten the screws using a $\frac{5}{32}$ -inch hex wrench.
4. Line up the two small tabs at the bottom of the console's back cover with the slots at the bottom of the console case. Insert the tabs into the slots.
5. Insert the two #8-32 x $\frac{1}{2}$ -inch Phillips-head screws that you removed earlier into the holes at the top edge of the console's back cover. Tighten the screws fully.
Important: Use caution not to pinch the cables between the back cover and PVS mounting screw heads.
6. Fully tighten the four mounting screws (partially tightened in step 3) using a $\frac{5}{32}$ -inch hex wrench.

Verifying That the Heart Rate Display Is Operational

To verify that the heart rate display is operational:

1. Begin exercising on the equipment.
2. Grasp both touch-sensitive handlebars.
Note: The heart rate is read within ten seconds. During that time, the heart on the display flashes. You must maintain contact with both metal plates on each handlebar to ensure an accurate reading.
3. Look at the HEART RATE display. After a few seconds, a number appears indicating your heart rate.
4. If a number does not appear in the HEART RATE display, perform the following checks:
 - Verify that the cable connection is properly connected.
 - Repeat the test with a different person. Although the heart rate display is generally highly accurate, it may not work properly for a few individuals.

Note: If you use wireless heart rate monitoring, repeat this test using a chest strap or a wireless pulse simulator instead of grasping the touch-sensitive handlebars.

Maintenance

To keep the equipment functioning properly, perform the minor maintenance tasks in this section at the intervals shown on the maintenance checklist. Failure to maintain the equipment as described in this section could void the Precor Limited Warranty.

DANGER To reduce the risk of electrical shock, always disconnect the equipment from its power source before cleaning it or performing any maintenance tasks. If the equipment is self-powered but also uses the optional power adapter, disconnect the adapter.

Daily Cleaning

Precor recommends that you clean the equipment before and after each exercise session. To remove dust and dirt from the equipment, wipe all exposed surfaces with a soft cloth that you have moistened with one of the following cleaners:

- A solution of 30 parts of water to 1 part of Simple Green® (for more information, visit www.simplegreen.com)
- ENVIR-O-SAFE oxygen enhanced cleaner or multi-task cleaner concentrate, diluted according to the manufacturer's instructions (for more information, visit www.daleyinternational.com)

Alternatively, you can clean the equipment with Athletix fitness equipment cleaning wipes (for more information, visit www.athletixproducts.com)

CAUTION: Read and follow the manufacturer's instructions, particularly dilution instructions, before using any cleaner on Precor fitness equipment. Do not use concentrated cleaners at full strength, or acidic cleaners of any kind; such cleaners weaken the protective finish on the equipment and void the Precor Limited Warranty. Never pour water or spray liquids onto any part of the equipment. Allow the equipment to dry completely before using.

Vacuum the floor underneath the equipment frequently to prevent the accumulation of dust and dirt that can interfere with its operation. Use a soft nylon scrub brush to clean the grooves on equipment with foot pedals.

Daily Inspection

At least once every day, examine the equipment for the following problems:

- Slipping belts
- Loose fasteners
- Unusual noises
- Worn or frayed power cords
- Any other indication that the equipment may be in need of service

Important: *If you determine that the equipment needs service, disconnect all power connections (television, Ethernet, and power) and move the equipment away from the exercise area. Place an OUT OF SERVICE sign on the equipment and make it clear to all patrons and other users that they must not use it.*

To order parts or to contact a Precor authorized service provider in your area, refer to *Obtaining Service*.

Cleaning the P80 Console and Display

The console and screen require little maintenance once installed. Precor recommends that you clean the console and screen before and after each exercise session.

To remove dust and dirt from the console:

- Wipe all exposed surfaces with a soft cloth that you have moistened with a solution of 30 parts of water to 1 part of Simple Green® (for more information, visit www.simplegreen.com).

To clean the screen:

- The manufacturer recommends diluting one part 91% isopropyl alcohol solution in one part water, or using the 91% isopropyl alcohol solution in its original strength. Be sure to follow the solvent manufacturer's precautions and directions when using any solvent.

CAUTION: Potentially hazardous situations associated with the use of isopropyl alcohol may result in minor or moderate injury and property damage. To avoid these situations, follow all instructions and recommendations in the manufacturer's Material Safety Data Sheet and product label.

Important: Do not use any acidic cleaners. Doing so will weaken the paint or powder coatings and void the Precor Limited Warranty. Never pour water or spray liquids directly on the console or console's screen.

- It is important to avoid using any corrosive chemicals on the console or screen.
- Always dampen the cloth and then clean the screen. Be sure to spray the cleaning liquid onto the cloth, not the screen, so that drips do not seep into the console.
- Apply the cleaner with a soft, lint-free cloth. Avoid using gritty cloths.

Weekly Maintenance

Perform the following maintenance tasks every week:

1. Disconnect the external power supply.
2. Clean the floor under the equipment using a vacuum cleaner or a damp mop.
3. When the floor is completely dry, reconnect the power (if necessary).
4. Test all console functions, including heart rate monitoring features.
5. Verify that the unit sits squarely on the floor. All of its feet should be touching the floor and the unit should not rock or wobble when in use. If not, re-level it as described in *Leveling the AMT*.

Monthly Maintenance

Perform the following maintenance tasks every month:

1. Wipe the exterior of the console with a damp sponge or soft cloth, and dry with a clean towel. Keep water away from electronic components to prevent electrical shock or damage.
2. Clean the touchscreen using a soft, lint-free cloth dampened with a 91% isopropyl alcohol solution (either as sold or diluted with an equal amount of water).
3. Wipe down the pedal belts using a clean, dry cloth.
Important: Do not use any cleaning solution or solvent on the pedal belts. Over time, cleaners can cause the outer layers of the belts to deteriorate.
4. Remove the access covers. Vacuum out any debris, being careful not to bring the vacuum cleaner nozzle too close to any circuit board (unless your vacuum cleaner is protected against static buildup).
5. Check the belt tension of the primary, brake, and drive belts (refer to the service manual for detailed instructions).
6. Check all fasteners for proper tightness and torque.
7. Replace all covers.
8. Verify that the unit sits squarely on the floor. All of its feet should be touching the floor and the unit should not rock or wobble when in use. If not, re-level it as described in *Leveling the AMT*.

Changing the Belt (Newer Model AMT Only)

The newer model AMT uses belts to provide motion. These belts eventually wear and must be replaced.

When the belt stride count reaches 90 million, the message **BELTS MUST BE CHANGED SOON** scrolls on the Welcome screen. While this message appears, the AMT operates normally.

Important: *If this message displays on your AMT, please contact Precor Customer Support for assistance.*

When the belt stride count reaches 100 million (and the belt has not been changed), the message **BELTS CHANGE REQUIRED** scrolls continuously on the Welcome screen. The input keys are not functional and the user cannot enter values or begin a workout until the belts are changed. Please contact Precor Customer Support to schedule a belt change.

Storing the Chest Strap

If you purchased the optional heart rate chest strap, store it in a place where it remains free of dust and dirt (for example, in a closet or drawer). Be sure to protect the chest strap from extremes in temperature. Do not store it in a place that may be exposed to temperatures below 32° F (0° C).

To clean the chest strap, use a sponge or soft cloth dampened in mild soap and water. Dry the surface thoroughly with a clean towel.

Moving the Equipment

The equipment is very heavy. If you plan to move it to a new location, obtain the help of an adult assistant and use proper lifting techniques. If the equipment includes roller wheels on one end, use the wheels to reduce the load on yourself and your assistant.

To move the AMT:

1. Disconnect, unplug, and remove all external connections (television, Ethernet, and power).
2. Lift the rear platform molding to remove it.
3. Lift the rear foot supports to tip the AMT forward onto its roller wheels.
4. Push the AMT into its new location.
5. Lower the rear foot supports to the floor, then reattach the rear platform molding.

Long-Term Storage

If you do not expect anyone to use the equipment for a long time, perform the following tasks to prepare it for storage:

- If it has a power cord, disconnect the cord.
- If it has an optional power adapter, connect the adapter to prevent damage to the internal battery.
- Position it so that it will not become damaged and will not interfere with people or other equipment.

Self-Powered Features

Important: This chapter of the manual describes Precor fitness equipment that can operate without being connected to AC power. This includes units equipped with P30 or P10 consoles. However, P80 consoles must be connected to AC power through their power supplies to operate. For this reason, this chapter does not apply to units equipped with P80 consoles.

On self-powered equipment, the system initializes and displays the Welcome screen when a user starts exercising. A minimum rate of motion must be maintained for the banner to appear, as shown in the following table. When a person meets the requirements, the power that is generated allows the equipment to function properly.

Table 4. Minimum requirements for operation

Equipment	Rate of Motion
AMT	40 strides per minute (SPM)
EFX	40 strides per minute (SPM)
Climber	30 steps per minute
Bike	20 revolutions per minute (RPM)

Informational displays appear when the battery is low or when the rate of motion drops below the minimum requirements. The display explains what to do to retain power. If the messages are ignored, the equipment begins shutdown procedures to maintain the charge of the battery. Refer to *Informational Displays Prior to Shutdown*.

An optional power adapter can be purchased and provides sustained power to the equipment. If you plan to change the club settings on a unit equipped with a P30 or P10 console, the power adapter is highly recommended. To purchase the optional power adapter, check with your dealer. Refer to *Obtaining Service*.

Informational Displays Prior to Shutdown

The equipment saves its battery charge by moving into a shutdown mode. If the user does not maintain the minimum rate of motion, a 30-second shutdown process begins.

In this mode, the console displays a countdown indicator and ignores all keypresses. If no movement is detected or the rate of motion remains below the minimum, the indicator changes as the countdown continues.

Note: The user can resume exercising before the countdown period elapses and the workout will continue from the point at which it was paused.

Important: *If the equipment is connected to a CSAFE master device, it follows a slightly different shutdown process. Ten seconds before the equipment shuts down, it ends the exercise session and displays a reset message while it disconnects from the CSAFE master device. It ignores all keypresses during these last ten seconds.*

Symptoms of a Low Battery

If no one has used the equipment for an extended period of time, the battery may need recharging.

Symptoms of a low battery include the following:

- A flickering or erratic display
- Loss of user and program information after the user stops exercising, without any display of a workout summary or a notification of pending shutdown
- Inability to decrease the incline setting (if any)

Important: *To maintain a constant power source, use the optional power adapter.*

Using the Optional Power Adapter

After connecting the power adapter to the equipment, plug the opposite end into the appropriate power source (120 V or 240 V).

CAUTION: When the optional power adapter is in use, make sure that the power supply cord does not create a safety hazard. Keep it out of the way of traffic and moving parts. If the power supply cord or power conversion module is damaged, it must be replaced.

The control console functions differently when the power adapter is connected. Because the power adapter provides a constant source of power, a user can pause for brief periods without initiating shutdown procedures. When the pause time limit expires and the user has not resumed exercising, the console returns to the Welcome screen. The default pause time is 30 seconds for all fitness equipment. Refer to the manual for your control console for instructions on setting or changing the pause time limit. To learn how to install the power adapter, refer to *The Optional Power Adapter Kit*.

The Optional Power Adapter Kit

If you purchase the optional power adapter, you must also purchase the internal cable kit. The kit supplies the cable, bracket, and fasteners that connect the power adapter to the lower electronics board.

CAUTION: The internal cable kit must be installed by authorized service personnel. Do not attempt installation on your own as you could void the Precor Limited Warranty. For more information, refer to *Obtaining Service*.

Important: *If this equipment includes a P80 console, the optional power adapter and the internal cable kit must still be installed to provide continuous power to the base unit and support its internal battery.*

Once the internal cable kit is installed, you can plug the optional power adapter into the equipment. Plug the opposite end into the appropriate power source for your equipment (120 V or 240 V). Review the safety instructions found at the beginning of this manual before using the power adapter.

Replacing the Battery

The equipment's battery is built to last for a long time. However, if you feel that the battery may need replacing, check with an authorized service technician. Refer to *Obtaining Service*.

CAUTION: The battery stored inside the equipment contains hazardous materials and must be disposed of according to Hazardous Waste Regulations. Refer to *Hazardous Materials and Proper Disposal*.

Commercial Cardiovascular Equipment Limited Warranty

PLEASE READ THESE WARRANTY TERMS AND CONDITIONS CAREFULLY BEFORE USING YOUR PRECOR INCORPORATED PRODUCT. BY USING THE EQUIPMENT, YOU ARE CONSENTING TO BE BOUND BY THE FOLLOWING WARRANTY TERMS AND CONDITIONS.

Limited Warranty.

Precor Incorporated warrants all new Precor products to be free from defects in materials and manufacture for the warranty periods set forth below. The warranty periods commence on the invoice date of the original purchase. This warranty applies only against defects discovered within the warranty period and extends only to the original purchaser of the product. Parts repaired or replaced under the terms of this warranty will be warranted for the remainder of the original warranty period only. To claim under this warranty, the buyer must notify Precor or your authorized Precor dealer within 30 days after the date of discovery of any nonconformity and make the affected product available for inspection by Precor or its service representative. Precor's obligations under this warranty are limited as set forth below.

Warranty Periods and Coverage.

All Commercial Cardiovascular Products (excluding StretchTrainer, Strength Products, and coverage specific to certain models and options as defined below):

- Frame: 7 years
- Treadmill drive motor: 5 years
- Items subject to wear: 1 year
- All other parts (including mechanical parts and electronic parts): 2 years
- Labor: 1 year

880 Line Commercial Cardiovascular Products (superseding the coverage above where applicable):

- Labor on the P80 console: 2 years
- High wear items on the P80 console, including headphone jack, USB connector, and iPod® connector: 90 days

Options / Accessories

Many options or accessories have components that are connected internally or mounted inside the electronic console. The following guidelines determine the warranty for these components. If the internal components are installed by the factory or by an authorized dealer as part of the original sale and delivery, they have a warranty that is identical to the warranty of the equipment in which they are connected or mounted. If the internal components are not installed by the factory or by an authorized dealer as part of the original sale and delivery, they have a 90 days parts and labor limited warranty. All components that are not internally connected have a 90 days parts only limited warranty. Satisfactory proof of purchase is required in all cases.

Conditions and Restrictions.

This warranty is valid only in accordance with the conditions set forth below:

1. The warranty applies to the Precor product only while
 - a. it remains in the possession of the original purchaser and proof of purchase is demonstrated.
 - b. it has not been subjected to accident, misuse, abuse, improper service, or non-Precor modification.
 - c. claims are made within the warranty period.
2. This warranty does not cover damage or equipment failure caused by electrical wiring not in compliance with electrical codes or Precor owner's manual specifications, or failure to provide reasonable and necessary maintenance as outlined in the owner's manual.
3. Precor is not responsible for Internet connectivity to its products. This restriction applies to services, such as those provided by an Internet service provider (ISP), and also to hardware related to Internet connectivity, such as Ethernet cabling, routers, servers and switches.
4. Precor is not responsible for the quality of television, video, audio, or other media supplied to its products. This restriction applies to services, such as those provided by a cable or satellite television provider; to signal strength and clarity; and also to hardware related to the reception and delivery of television, video, audio, and other media. Such hardware can include (but is not limited to) audio, video, and radio-frequency (RF) cabling, connectors, receivers, modulators, combiners, distribution amplifiers, splitters, and so on.
5. Precor cannot guarantee that the heart rate measurement system on its products will work for all users. Heart rate measurement accuracy varies based on a number of factors, including the user's physiology and age, the method in which the heart rate measurement system is used, external interference, and other factors that may influence heart rate acquisition.
6. Except in Canada, Precor does not pay labor outside the United States.
7. Warranties outside the United States and Canada may vary. Please contact your local Dealer for details.

This Limited Warranty shall not apply to:

1. Software version upgrades.
2. Software defects that do not materially and negatively affect the normal performance of the product under normal conditions of use.
3. Consumable goods or cosmetic items of the product, the exterior of which has been damaged or defaced as a result of abuse, misuse, accident, improper service or installation, mishandling, or modification in design or construction not authorized by Precor.
4. Repairs performed on Precor equipment missing a serial number or with a serial tag that has been altered or defaced.
5. Service calls to correct installation of the equipment or instruct owners on how to use the equipment.
6. Pickup and delivery involved with repairs.
7. Any labor costs incurred beyond the applicable labor warranty period.

Disclaimer and Release.

The warranties provided herein are the exclusive warranties given by Precor and supersede any prior, contrary or additional representations, whether oral or written. ANY IMPLIED WARRANTIES, INCLUDING THE WARRANTY OF MERCHANTABILITY OR FITNESS FOR A PARTICULAR PURPOSE THAT APPLY TO ANY PARTS DESCRIBED ABOVE ARE LIMITED IN DURATION TO THE PERIODS OF EXPRESS WARRANTIES GIVEN ABOVE FOR THOSE SAME PARTS. PRECOR HEREBY DISCLAIMS AND EXCLUDES THOSE WARRANTIES THEREAFTER. Some States do not allow limitations on how long an implied warranty lasts, so the above limitation may not apply to you. PRECOR ALSO HEREBY DISCLAIMS AND EXCLUDES ALL OTHER OBLIGATIONS OR LIABILITIES, EXPRESS OR IMPLIED, ARISING BY LAW OR OTHERWISE, WITH RESPECT TO ANY NONCONFORMANCE OR DEFECT IN ANY PRODUCT, INCLUDING BUT NOT LIMITED TO: (A) ANY OBLIGATION, LIABILITY, RIGHT, CLAIM OR REMEDY IN TORT, WHETHER OR NOT ARISING FROM THE NEGLIGENCE OF PRECOR OR ITS SUPPLIERS (WHETHER ACTIVE, PASSIVE OR IMPUTED); AND (B) ANY OBLIGATION, LIABILITY, RIGHT, CLAIM OR REMEDY FOR LOSS OF OR DAMAGE TO ANY EQUIPMENT. This disclaimer and release shall apply even if the express warranty set forth above fails of its essential purpose.

Exclusive Remedies.

For any product described above that fails to conform to its warranty, Precor will provide, at their option, one of the following: (1) repair; (2) replacement; or (3) refund of the purchase price. Precor Limited Warranty service may be obtained by contacting the authorized dealer from whom you purchased the item. Precor compensates Servicers for warranty trips within their normal service area to repair commercial equipment at the customer's location. You may be charged a trip charge outside the service area. THESE SHALL BE THE SOLE AND EXCLUSIVE REMEDIES OF THE BUYER FOR ANY BREACH OF WARRANTY.

EXCLUSION OF CONSEQUENTIAL AND INCIDENTAL DAMAGES.

PRECOR AND/OR ITS SUPPLIERS SHALL HAVE NO OBLIGATION OR LIABILITY, WHETHER ARISING IN CONTRACT (INCLUDING WARRANTY), TORT (INCLUDING ACTIVE, PASSIVE, OR IMPUTED NEGLIGENCE AND STRICT LIABILITY), OR OTHERWISE, FOR DAMAGE TO THE EQUIPMENT, PROPERTY DAMAGE, LOSS OF USE, REVENUE OR PROFIT, COST OF CAPITAL, COST OF SUBSTITUTE EQUIPMENT, ADDITIONAL COSTS INCURRED BY BUYER (BY WAY OF CORRECTION OR OTHERWISE) OR ANY OTHER INCIDENTAL, SPECIAL, INDIRECT, OR CONSEQUENTIAL DAMAGES, WHETHER RESULTING FROM NONDELIVERY OR FROM THE USE, MISUSE OR INABILITY TO USE THE PRODUCT. This exclusion applies even if the above warranty fails of its essential purposes and regardless of whether such damages are sought for breach of warranty, breach of contract, negligence, or strict liability in tort or under any other legal theory. Some states do not allow the exclusion or limitation of incidental or consequential damages, so the above limitation may not apply to you.

This warranty gives you specific legal rights, and you may also have other rights, which vary from state to state.

Complete this portion and keep for your records.

Purchased From: _____
Example: Dealer or store name.

Phone Number: _____
Example: Dealer or store telephone number.

Product/model: _____
Example: AMT 885 or EFX 883.

Serial number: _____
The serial number is found on the shipping container.

Effective 1 November 2010
P/N 36286-114

Notes:

Notes:



Precor Incorporated
20031 142nd Avenue NE
P.O. Box 7202
Woodinville, WA USA 98072-4002



AMT G2 PAG/OM 301704-301 rev E, en
Warranty #36286-114
October 2012