

Assembling and Maintaining Adaptive Motion Trainers[®]

AMT[®] 885 • AMT[®] 835



PRECOR[®]

Assembling and Maintaining Adaptive Motion Trainers®

AMT® 885 • AMT® 835

PRECOR®

Edition Information

ASSEMBLING AND MAINTAINING ADAPTIVE MOTION
TRAINERS: AMT 885 /835

P/N 300710-301 rev F

Copyright © February 2011 Precor Incorporated. All rights reserved. Specifications subject to change without notice.

Trademark Note

Precor, AMT, and EFX are registered trademarks and Preva is a trademark of Precor Incorporated. Other names in this document may be the trademarks or registered trademarks of their respective owners.

The Precor AMT is protected by one or more of the following US and foreign patents:

- US 7,530,926
- US 7,520,839

Other US and foreign patents pending.

Intellectual Property Notice

All rights, title, and interests in and to the software of the Preva Business Suite, the accompanying printed materials, any copies of such software, and all data collected via the Preva Business Suite, are exclusively owned by Precor or its suppliers, as the case may be.

Precor is widely recognized for its innovative, award-winning designs of exercise equipment. Precor aggressively seeks U.S. and foreign patents for both the mechanical construction and the visual aspects of its product design. Any party contemplating the use of Precor product designs is hereby forewarned that Precor considers the unauthorized appropriation of its proprietary rights to be a very serious matter. Precor will vigorously pursue all unauthorized appropriation of its proprietary rights.

Precor Incorporated
20031 142nd Ave NE, P.O. Box 7202
Woodinville, WA 98072-4002
1-800-347-4404

<http://www.precor.com>

Important Safety Instructions

Read the following precautions thoroughly before you begin assembly, and save them afterward for future reference.

Safety Precautions

Always follow basic safety precautions when using this equipment to reduce the chance of injury, fire, or damage. Other sections in this manual provide more details of safety features. Be sure to read these sections and observe all safety notices. These precautions include the following:

- Read all instructions in this guide before installing and using the equipment and follow any labels on the equipment.
- Make sure all users see a physician for a complete physical examination before they begin any fitness program.
- *Il est conseillé de subir un examen médical complet avant d'entreprendre tout programme d'exercice. Si vous avez des étourdissements ou des faiblesses, arrêtez les exercices immédiatement.*
- Do not allow children, or people unfamiliar with the operation of this equipment, on or near it. Do not leave children unsupervised around the equipment.
- Make sure all users wear proper exercise clothing and shoes for their workouts and avoid loose or dangling clothing. Users should not wear shoes with heels or leather soles, and they should check the soles of their shoes to remove any dirt and embedded stones. They should also tie long hair back.
- Never leave the equipment unattended when it is plugged in. Unplug the equipment from its power source when it is not in use, before cleaning it, and before providing authorized service.

Note: The optional power adapter is considered a power source for self-powered equipment.

- Use the power adapter provided with the equipment. Plug the power adapter into an appropriate, grounded power outlet as marked on the equipment.
- Care should be taken when mounting or dismounting the equipment.
- Read, understand, and test the emergency stop procedures before use.
- Keep the power cord or optional power adapter and plug away from heated surfaces.
- Route power cables so that they are not walked on, pinched, or damaged by items placed upon or against them, including the equipment itself.
- Ensure the equipment has adequate ventilation. Do not place anything on top of or over the equipment. Do not use on a cushioned surface that could block the ventilation opening.
- Assemble and operate the equipment on a solid, level surface.
- Proper Location for Equipment
 - For all equipment other than treadmills: Locate at least 40 inches (1 meter) away from walls or furniture on either side of the equipment, and 40 inches (1 meter) away from objects behind the equipment.
 - For treadmills: Locate at least 40 inches (1 meter) away from walls or furniture on either side of the treadmill, and at least 80 inches (2 meters) away from objects behind the treadmill.

Important: These location standards should also be used when positioning equipment away from sources of heat, such as radiators, heat registers, and stoves. Avoid temperature extremes.

- Keep equipment away from water and moisture. Avoid dropping anything on or spilling anything inside the equipment to prevent electric shock or damage to the electronics.
- Do not operate electrically powered equipment in damp or wet locations.
- Never operate this equipment if it has a damaged cord or plug, if it is not working properly, or if it has been dropped, damaged, or exposed to water. Call for service immediately if any of these conditions exist.

- Maintain the equipment to keep it in good working condition, as described in the *Maintenance* section of the assembly and maintenance guide. Inspect the equipment for incorrect, worn, or loose components, and then correct, replace or tighten prior to use.
- If you plan to move the equipment, obtain help and use proper lifting techniques. refer to the "Moving the Equipment" section of the assembly and maintenance guide.
- Use the equipment only for its intended purpose as described in this manual. Do not use accessory attachments that are not recommended by Precor. Such attachments may cause injuries.
- Do not operate the equipment where aerosol (spray) products are being used or where oxygen is being administered.
- Do not use outdoors.
- Do not attempt to service the equipment yourself, except to follow the maintenance instructions in this manual.
- Never drop or insert objects into any opening. Keep hands away from moving parts.
- Do not set anything on the stationary handrails, handlebars, control console, or covers. Place liquids, magazines, and books in the appropriate receptacles.
- Do not lean on or pull on the console at any time.



CAUTION: DO NOT remove the cover, or you may risk injury due to electric shock. Read the assembly and maintenance guide before operating. There are no user-serviceable parts inside. Contact Customer Support if the equipment needs servicing. For use with single phase AC supply only.

Educating Users

Take time to educate users about the Important Safety Instructions found in both the *User Reference Manual* and *Product Owner's Manual*. Explain to your club or facility patrons that they should observe the following precautions:

- Hold onto a stationary handrail or handlebar while assuming the starting position on the equipment.
- Face the console at all times.
- Hold on to a stationary handrail or handlebar with one hand whenever you operate the console keys with the other hand.

Hazardous Materials and Proper Disposal

The batteries within self-powered equipment contain materials that are considered hazardous to the environment. Federal law requires proper disposal of these batteries.

If you plan to dispose of your equipment, contact Precor Commercial Products Customer Support for information regarding battery removal. Refer to *Obtaining Service*.

Product Recycling and Disposal

This equipment must be recycled or discarded according to applicable local and national regulations.

Product labels, in accordance with European Directive 2002/96/EC concerning waste electrical and electronic equipment (WEEE), determine the framework for the return and recycling of used equipment as applicable throughout the European Union. The WEEE label indicates that the product is not to be thrown away, but rather reclaimed upon end of life per this Directive.

In accordance with the European WEEE Directive, electrical and electronic equipment (EEE) is to be collected separately and to be reused, recycled, or recovered at end of life. Users of EEE with the WEEE label per Annex IV of the WEEE Directive must not dispose of end of life EEE as unsorted municipal waste, but use the collection framework available to customers for the return, recycling, and recovery of WEEE. Customer participation is important to minimize any potential effects of EEE on the environment and human health due to the potential presence of hazardous substances in EEE. For proper collection and treatment, refer to *Obtaining Service*.

Regulatory Notices for the RFID Module

When equipped with a control console as described in this document, this equipment may include a radio-frequency identification (RFID) module. The RFID module has been certified to operate at temperatures between -20°C and 85°C (-4°F and 185°F).

Radio Frequency Interference (RFI)

The RFID module conforms to the following national standards defining acceptable limits for radio frequency interference (RFI).

Federal Communications Commission, Part 15

This equipment has been tested and found to comply with the limits for a Class A digital device, pursuant to Part 15 of the FCC Rules. These limits are designed to provide reasonable protection against harmful interference in a commercial installation. The equipment generates, uses, and can radiate radio frequency energy and, if not installed and used in accordance with the owner's manual instructions, can cause harmful interference to radio communications.

Operation is subject to the following two conditions: (1) this device may not cause harmful interference, and (2) this device must accept any interference received, including interference that may cause undesired operation.

WARNING Per FCC rules, changes or modifications not expressly approved by the manufacturer could void the user's authority to operate the equipment.

Industry Canada

This device complies with RSS-210:2007 of the Spectrum Management & Telecommunications Radio Standards Specification. Operation is subject to the following two conditions: (1) this device may not cause harmful interference, and (2) this device must accept any interference received, including interference that may cause undesired operation.

This Class A digital apparatus complies with Canadian ICES-003.

Cet appareil numérique de la classe A est conforme à la norme NMB-003 du Canada.

ATTENTION: Haute Tension
Débranchez avant de réparer

European Applications

CE compliance is claimed to the following directives:

- 1999/5/EC R&TTE Directive
- 2006/95/EC LVD Directive
- 2002/95/EC RoHS Directive

Directive compliance has been verified to the following standards:

- EN 55022
- EN 300 330-1 V1.5.1
- EN 300 330-2 V1.3.1
- EN 301 489-3 V1.4.1
- EN 301 489-1 V1.8.1
- EN 60950-1

Regulatory Notices for Cardiovascular Exercise Equipment

The regulatory information in this section applies to the exercise equipment and its control console.

Safety Approvals for Cardiovascular Equipment

Precor equipment has been tested and found to comply with the following applicable safety standards.

Cardiovascular Type Equipment:

- CAN/CSA, IEC, EN 60335-1 (Household and similar electrical appliances - Safety)
- EN 957 (Stationary training equipment, class S/B compliant equipment)

PVS and P80 Regulatory Notice

This Precor equipment has been tested and found to comply with the following applicable safety standards.

- CAN/CSA, UL, IEC, EN 60065 (Audio, video and similar electronic apparatus - Safety)

Radio Frequency Interference (RFI)

This Precor exercise equipment conforms to the following national standards defining acceptable limits for radio frequency interference (RFI).

Federal Communications Commission, Part 15

This equipment has been tested and found to comply with the limits for a Class A digital device, pursuant to Part 15 of the FCC Rules. These limits are designed to provide reasonable protection against harmful interference in a commercial installation. The equipment generates, uses, and can radiate radio frequency energy and, if not installed and used in accordance with the owner's manual instructions, may cause harmful interference to radio communications.

WARNING Per FCC rules, changes or modifications not expressly approved by Precor could void the user's authority to operate the equipment.

Industry Canada

This Class A digital apparatus complies with Canadian ICES-003.

Cet appareil numérique de la classe A est conforme à la norme NMB-003 du Canada.

ATTENTION: Haute Tension
Débranchez avant de réparer

European Applications

CE compliance is claimed to the following directives:

- 2004/108/EC EMC Directive
- 2006/95/EC LVD Directive
- 2002/95/EC RoHS Directive

Directive compliance has been verified to the following standards:

- EN 55022
- EN 55024
- EN 60335-1
- EN 60065 (P80 and PVS)

Electrical Recommendations: All Equipment Excluding Treadmills

Note: This is a recommendation only. NEC (National Electric Code) guidelines or local region electric codes must be followed.

For equipment fitted with a P80 console or Personal Viewing System (PVS) screen a separate power connection is required. For a 20 amp branch circuit up to 10 screens can be connected. If the branch circuit has any other devices plugged into the circuit the number of screens must be reduced by the wattage of the other devices.

Note: The typical splitter power cords that have IEC-320 C13 and C14 plugs have a recommended maximum capacity of five screens.

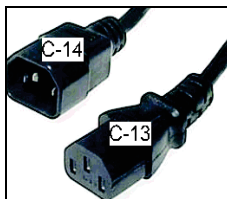

Figure 1: IEC-320 C13 and C14 plugs

Obtaining Service

Do not attempt to service the equipment except for maintenance tasks. If any items are missing, contact your dealer. For more information regarding customer support numbers or a list of Precor authorized service centers, visit the Precor web site at <http://www.precor.com>.

Obtaining Updated Documentation

Current documentation for Experience Series consoles and Preva Networked Fitness software is available at <http://www.precor.com/productmanuals>. You may want to check in for updated information from time to time as the universe of Preva features expands.

Table of Contents

Important Safety Instructions	5
Safety Precautions	5
Educating Users	8
Hazardous Materials and Proper Disposal	8
Product Recycling and Disposal.....	8
Regulatory Notices for the RFID Module.....	9
Regulatory Notices for Cardiovascular Exercise Equipment.....	11
Electrical Recommendations: All Equipment Excluding Treadmills	13
Obtaining Service	13
Obtaining Updated Documentation.....	13
Assembling the AMT	17
Hardware Kit (not to scale).....	18
Required Tools	19
Performing the Assembly	19
Removing Access Covers.....	22
Threading the Cables	22
Replacing Access Covers	24
Leveling the AMT	24
Breaking in the Equipment.....	26
Installing the Console	27
Threading the Cable Assembly (P80).....	27
Connecting Cables (P80)	29
Completing the Console Installation (P80).....	33
Threading the Cable Assembly (P30).....	33
Connecting Cables (P30)	35
Completing the Console Installation (P30)	36
Verifying That the Heart Rate Display Is Operational	36

Maintenance	37
Daily Cleaning.....	37
Daily Inspection.....	38
Weekly Maintenance.....	39
Monthly Maintenance	39
Storing the Chest Strap	40
Moving the Equipment	40
Long-Term Storage	40
Self-Powered Features	41
Informational Displays Prior to Shutdown.....	42
Symptoms of a Low Battery	42
Using the Optional Power Adapter.....	42
The Optional Power Adapter Kit	43
Replacing the Battery.....	43
Commercial Cardiovascular Equipment Limited Warranty	45

Assembling the AMT

Important: The instructions in the following procedures are described from the perspective of a person standing **directly in front of the equipment** (that is, on the opposite side of the control console from a person using the equipment). These descriptions may not match the names of certain parts in the parts list, because such parts are named relative to the back of the equipment.

To prepare the AMT for assembly:

- Open the box and assemble the components in the sequence presented in this guide.
- Assemble and operate your equipment on a hard, level surface in the area intended for use.

Important: Do not grasp any plastic parts of the unit while lifting or moving the unit. The plastic parts are non-structural covers and are not capable of supporting the weight of the unit.

- Provide ample space around the unit.
- Assemble the equipment according to the guidelines in this manual to ensure you do not void the Precor Limited Warranty.



Important: Any damage caused during installation is not covered by the Precor Limited Warranty.

- Attach all fasteners and partially tighten them. Do not fully tighten fasteners until instructed to do so.

WARNING You will need assistance to assemble this unit. **DO NOT attempt assembly by yourself.**

Hardware Kit (not to scale)

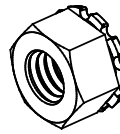
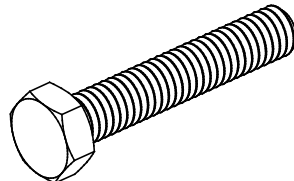
The hardware kit shipped with this equipment contains the fasteners and other hardware components shown in the following table. Before you begin assembly, make sure that your hardware kit is complete. If not, please contact Precor Customer Support.

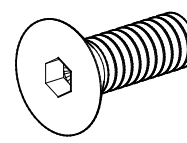
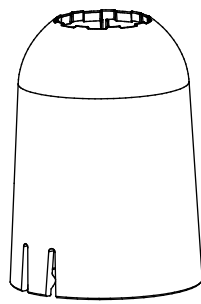
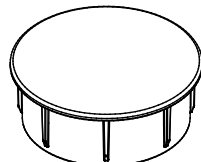
Fasteners		Quantity
	Locknuts (5/16-inch)	8
	Hex head screws (5/16-inch x 1 3/4-inch)	4
	Flat washers (5/16-inch)	8
	Flat head hex drive screws (1/4-inch x 3/4-inch)	4
	Plastic boots	2
	End caps	2

Required Tools

- $\frac{5}{16}$ -inch hex wrench
- $\frac{5}{32}$ -inch hex wrench
- #2 Phillips screwdriver
- Rubber mallet
- SAE standard socket set
- Wire cutter
- Torque wrench (calibrated in inch-pounds)

Performing the Assembly

DANGER Do not attempt to connect electrical power until all assembly procedures are complete and the console is properly installed.

Follow these steps to assemble the AMT base unit.

To begin assembly:

1. Remove the two side fasteners that hold the front frame tube to the shipping pallet and cut the tie wraps that secure the rear base.

CAUTION: Do not move the AMT off its shipping pallet without assistance. To avoid unnecessary movement of the foot plates, do not install the handlebars until you begin the next procedure.

2. Lift the rear base and roll the AMT forward while your assistant stabilizes the front base and guides it off the shipping pallet onto the floor.

Note: Begin assembly in the area intended for use.

3. Insert the end caps into the front frame tube. If necessary, use a rubber mallet to tap them into place.

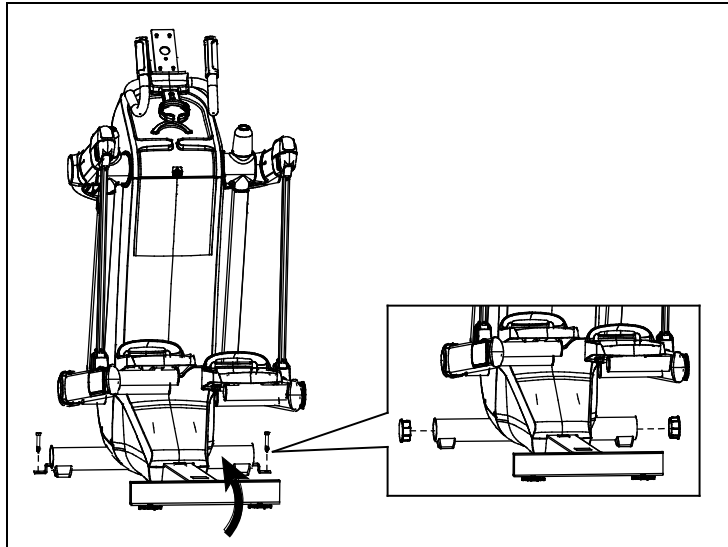

Figure 2: Removal of unit from pallet and insertion of end caps

To attach the handlebars:

1. Slide a plastic boot onto each handlebar.

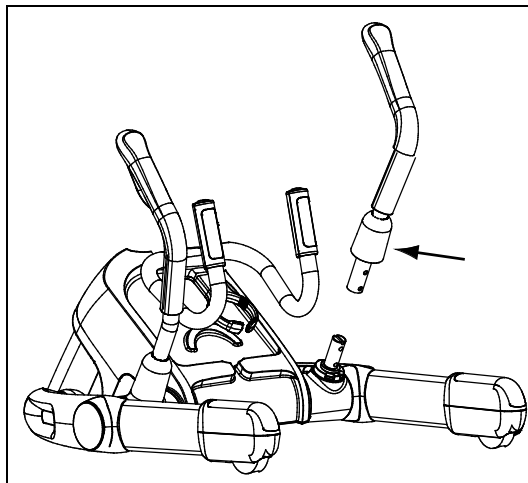

Figure 3: Boot attachment

2. Use the following graphic to determine the proper position of the handlebars.

Note: When the handlebars are mounted correctly, each bends slightly outward.

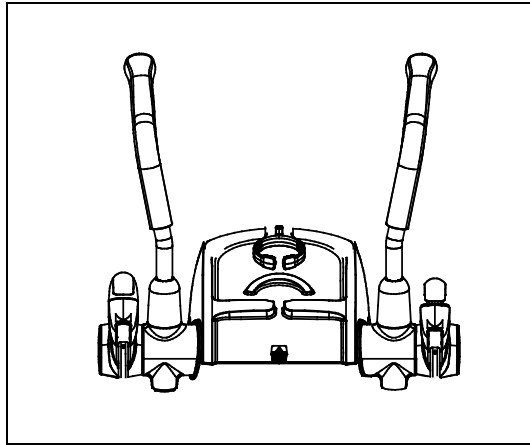

Figure 4: View of handlebar placement

3. Attach the handlebars using four $\frac{5}{16}$ -inch x $1\frac{3}{4}$ -inch hex head screws, eight $\frac{5}{16}$ -inch washers, and four $\frac{5}{16}$ -inch locknuts. Using a torque wrench, tighten the fasteners with 180 to 200 inch-pounds of torque.

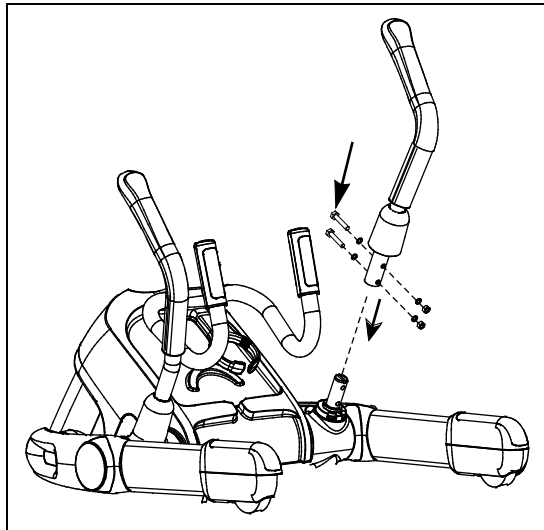

Figure 5: Handlebar attachment

4. Rotate the plastic boot so that its tab aligns with the cutout below it, and then press the boot downward to secure it in place.

Removing Access Covers

With its access covers removed, the AMT provides easy access to its cables and internal components.

Tip: In the following procedure, set aside the covers and their mounting hardware in groups, in the order in which you remove them. This simplifies reinstallation later.

To remove the access covers:

1. Using a rubber mallet or the heel of your hand, tap at an upward angle against the side of the top column cover to snap it loose.

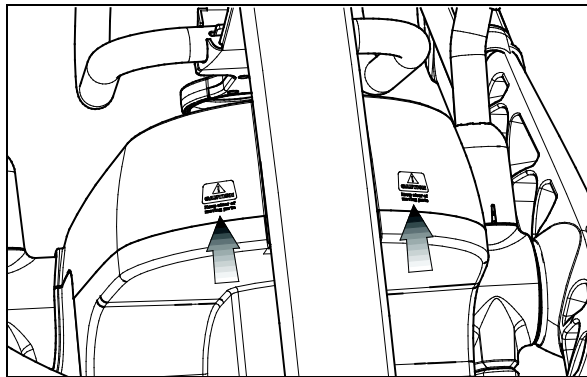

Figure 6: Where to place pressure when removing top cover

2. Lift the cover, then slide it toward the rear of the equipment and out.
3. Using a $\frac{5}{32}$ " hex wrench, disconnect the two 1-inch buttonhead screws at the bottom of the front cover, then snap the cover loose.

Threading the Cables

Depending on the model of console you are installing and the options it includes, you will need to install one or more of the following cables:

- Television (coaxial with F connectors)
- Power
- Ethernet

Precor recommends threading new cables from the top down, to take advantage of gravity. A fish tape (a thin metal strip with a hook or clasp on one end, available from professional hardware vendors) can be helpful during this procedure.

To thread new cables through the equipment:

1. Select the console power cable (red and black, individual leads), the Ethernet cable (flat and black), or the television cable (round and black).
2. Thread the cable through the center column at the front of the equipment.
3. Guide the end of the cable through the gap at the bottom of the center column, then attach it to the appropriate connector on the jack panel. Refer to the following illustration and table for the position of each connector.

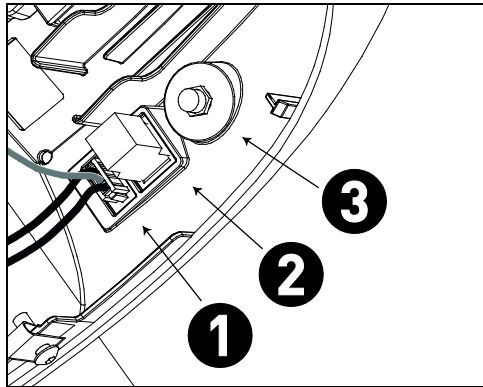

<i>Connect ...</i>	<i>To ...</i>
The console power cable	The power cable assembly 1
The Ethernet cable	The eight-connector modular jack on the jack panel 2
The television cable	The coaxial connector on the jack panel 3

4. Repeat steps 1 through 3 until all three cables are completely installed.
5. Insert all cables into the cable clips on the center frame pillar just below the bottom of the center column. Use plastic ties to bind the cables together below the clips and to route them away from any moving parts.

Replacing Access Covers

After you install the console cables, you can return the access covers to their previous positions on the equipment.

To replace the access covers:

1. Snap the front cover back into place. Reinsert the two buttonhead screws you removed with the front cover, then tighten them using a $\frac{5}{32}$ " hex wrench.
2. Position the top column cover between the handlebars and the body of the AMT. Make sure that the sides of the top column cover extend over the upper edges of the body covers, then use the heel of your hand or a rubber mallet to tap the cover back into place.

Leveling the AMT

It is important that you level and stabilize the AMT properly every time you move it.

CAUTION: To eliminate movement, make sure the adjustable feet are in contact with the floor. Also, make sure that the unit sits on a flat surface. Adjusting the feet of the unit cannot compensate for extremely uneven surfaces.

To level the AMT:

1. Gently rock the AMT while standing on one of its foot plates and grabbing the opposite handlebar. First stand on the left foot plate and grab the right handlebar to rock the AMT, then repeat the step while standing on the right foot plate and holding the left handlebar. If there is any movement, ask your assistant to tip the unit on its side while you locate the adjustable feet.

2. Reposition the adjustable feet as needed.

If you want to ...

Then turn the adjustable feet ...

Raise the front end of the AMT

Counterclockwise

Lower the front end of the AMT

Clockwise

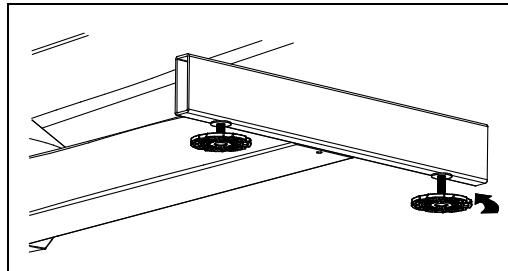

Figure 7: Location of adjustable feet

3. When you are finished positioning the adjustable feet, place the unit on the floor. Try rocking it again, as described in step 1, to verify that it is level.
4. To install the rear pedestal, align it over the rear crosspiece and press it gently into place.

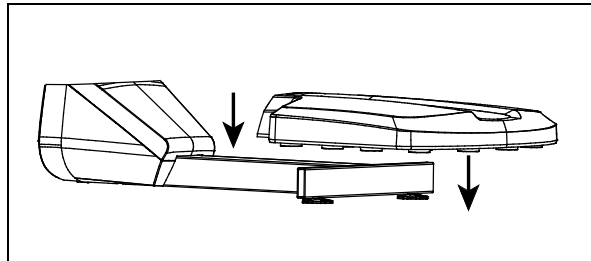

Figure 8: Rear pedestal placement

Breaking in the Equipment

Precor equipment does not require an actual break-in period. However, moving components such as belts, gears, and bearings can settle while the equipment is being stored or shipped. This can cause the equipment to operate with a small amount of roughness or noise when it starts up for the first time.

The equipment usually returns to smooth operation after a day or two of normal use. If it does not, contact your dealer for assistance. For more information, refer to *Obtaining Service*.

Installing the Console

To make installation easier, all Precor Experience Series consoles use the same mounting hardware and connector locations whenever possible. The installation sequence for any of them is as follows:

- Threading the cable assembly
- Connecting cables
- Completing the installation (tightening the mounting screws and attaching the back cover)

The following sections describe how to perform these tasks.

Threading the Cable Assembly (P80)

Earlier in the installation, you threaded the necessary cables through the frame of the base unit and out the passthrough opening in the console mount. As you line up the back plate on the console with the console mount, you must make sure that the cable assembly passes correctly through the openings in both components.

Important: Before you begin the following procedure, remove the rear cover from the control console. To remove the cover, use your fingernails to pry the lower edge loose, then swing the cover up and out as shown in the following illustration.

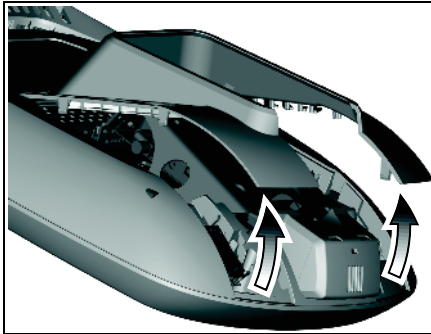

Figure 9: Removing the access cover from the P80 console

To thread the cable assembly:

1. Make sure that as much of each cable as possible passes through the opening in the middle of the console mount on the base unit.
2. Position the console over the console mount.
3. Rest the console on the console mount so that the notch on the bottom of the console's back plate rests on the rectangular hook at the bottom of the console mount, as shown in the following figure.

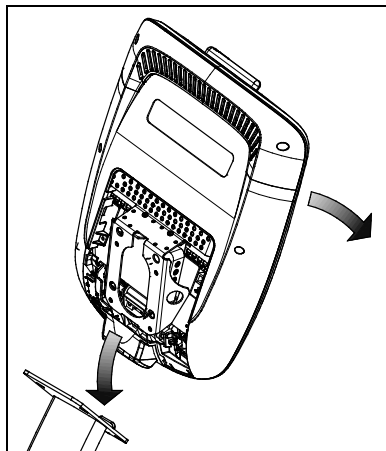

Figure 10: Console positioning on base unit

4. Tilt the console forward until it stops. Use one hand to steady the console in this position, or ask your assistant to do so.

Connecting Cables (P80)

After the console has been seated, separate the individual cables out of the end of the cable assembly and attach them to the appropriate circuit connectors inside the console. Refer to the following diagram and table to identify the cables and connectors.

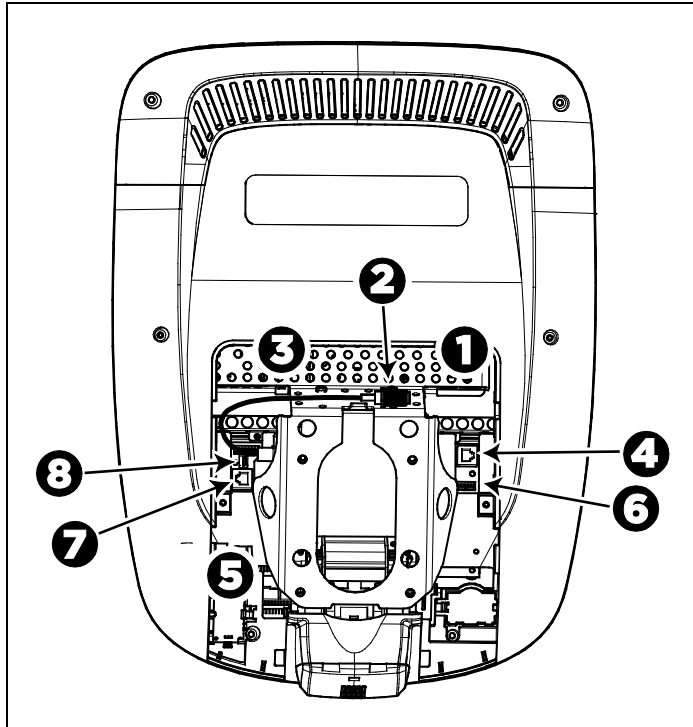

Figure 11: Cable connections, P80 console

Table 1. P80 internal cable connections

Cable	Connector Type	Circuit Connector Location
Ethernet (LAN)	Eight-contact modular, on round black cable	1
TV in	F-type coaxial	2
Power	Two-contact plug, polarized and latched	3
Data from base unit	Eight-contact modular, on flat gray cable	4

Cable	Connector Type	Circuit Connector Location
Heart rate sensors	Four-contact strip, keyed	5
Safety key (treadmills only)	Six-contact strip, keyed	6
CSAFE	Eight-contact modular, on flat gray cable	7
Auto Stop sensor (treadmills only)	Four-contact strip, keyed	8

To simplify installation and maintenance, route and connect cables 1 through 5 according to the following instructions.

Note: In the illustrations in this section, some cables are omitted for the sake of clarity.

Connecting the Television Cable

The console's television tuner is mounted inside the console's back plate. The tuner includes a short cable adapter that allows the television cable to be connected outside the back plate.

To connect the television cable:

1. Pull the cable out through the lower right corner of the back plate.
2. Route the cable counterclockwise around the outside of the back plate.
3. Attach the connector on the cable to the connector on the tuner cable and tighten the two connectors securely using two $\frac{7}{16}$ -inch open-end wrenches. Position both connectors above the upper right corner of the back plate.
4. Use a plastic tie to secure the connectors to the top of the back plate. Pass the tie through the two small holes near the upper right corner of the back plate, then wrap it around the connectors and tighten it securely. Cut off and remove the protruding end of the tie.

The following illustration shows how the cable is positioned once it is installed.

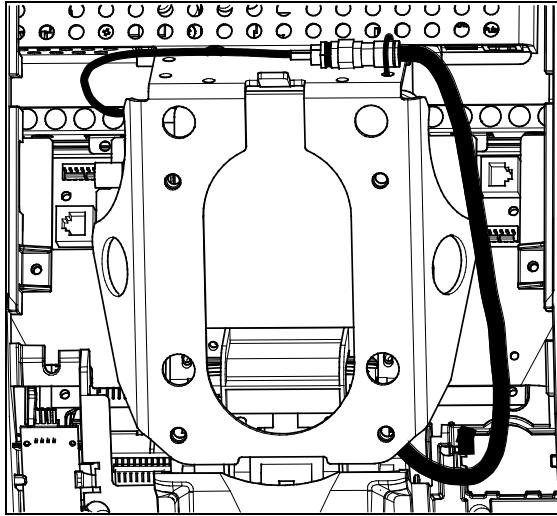

Figure 12: Connecting the television cable

Connecting the Ethernet and Base Unit Data Cables

Both the Ethernet and base unit data cables pass through the cutaway opening at the upper right corner of the back plate and connect to nearby modular jacks in the console. Because of this, it is important to exercise caution when connecting the cables. The black Ethernet cable connects to a jack just underneath the perforated metal bracket at the very top of the opening in the console. The gray base unit data cable connects to a lower jack closer to the back plate.

Refer to the following illustration for the correct position of both cables.

CAUTION: If you connect the base unit data cable to the wrong jack, the equipment will not function.

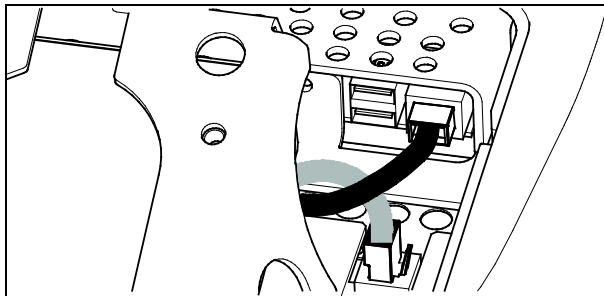

Figure 13: Connecting the Ethernet and base unit data cables

Connecting the Heart Rate Sensor Cable

The heart rate sensor cable passes through the cutaway opening at the upper left corner of the back plate, then down to the small circuit board at the lower left of the console. The following illustration shows how the cable should look once it is installed.

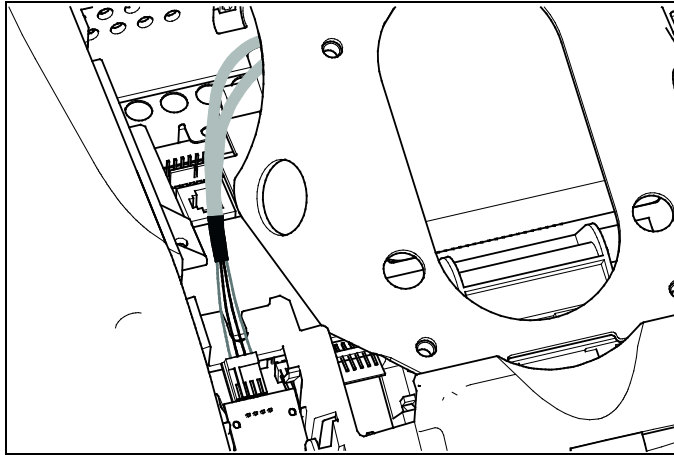

Figure 14: Connecting the heart rate cable

Connecting the Power Cable

Like the tuner, the console's upper circuit board is equipped with a cable adapter that relieves you of attempting to attach a cable to a recessed jack. To connect the power cable, route it through the cutaway opening at the upper left corner of the back plate and plug it into this adapter.

The following illustration shows how the cable should look once it is installed.

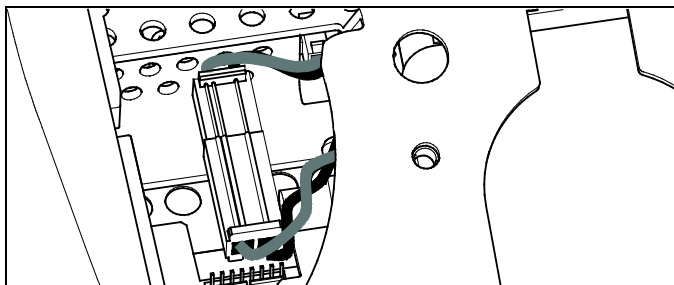

Figure 15: Connecting the power cable

Completing the Console Installation (P80)

Before you complete the final installation steps, double-check the connections you have made. Make sure that all cables are fully and securely connected, and that any unneeded cables are tied back properly.

To complete the installation:

1. Feed extra cable back into the neck tube.
2. Tilt the control console backward (toward yourself) until the tab on the top edge of its back plate slides along the top edge of the console mount and the screw holes align properly.
3. Insert the four $\frac{5}{8}$ -inch flat head screws through the holes in the console mount and thread them into the holes in the back plate on the console. Partially tighten the screws using a $\frac{5}{8}$ -inch hex wrench.
4. Line up the two small tabs at the top of the console's back cover with the slots at the top of the opening in the console case. Insert the tabs into the slots.
5. Insert the remaining tabs on the back cover with the corresponding slots on the console case.
6. Press gently on the edges of the back cover to snap it into place.

Threading the Cable Assembly (P30)

Earlier in the installation, you threaded the necessary cables through the frame of the base unit and out the passthrough opening in the console mount. As you line up the back plate on the console with the console mount, you must make sure that the cable assembly passes correctly through the openings in both components.

Important: Before you begin the following procedure, remove the rear cover from the control console. Set the cover and its mounting hardware aside for later use.

To thread the cable assembly:

1. Make sure that as much of each cable as possible passes through the opening in the middle of the console mount on the base unit.
2. Position the console over the console mount.
3. Rest the console on the console mount so that the notch on the bottom of the console's back plate rests on the rectangular hook at the bottom of the console mount, as shown in the following figure.

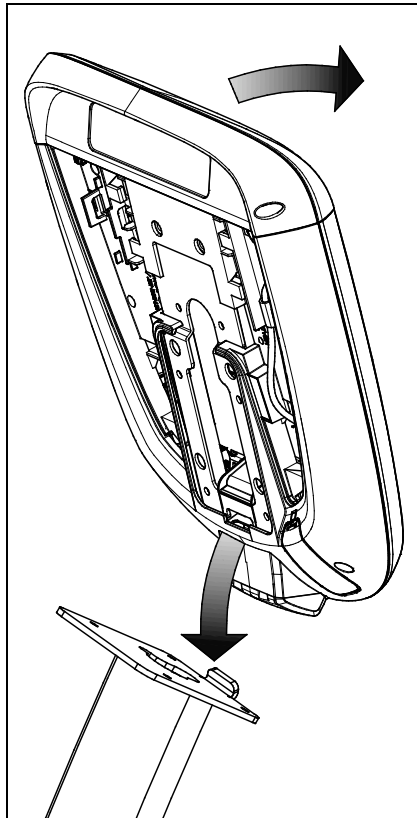
**Figure 16: Console positioning on base unit**

4. Tilt the console forward until it stops. Use one hand to steady the console in this position, or ask your assistant to do so.
5. Pull all cables upward and forward until you can drape them over the top of the console's back plate.

Connecting Cables (P30)

After the console has been seated, separate the individual cables out of the end of the cable assembly and attach them to the appropriate circuit connectors inside the console. Refer to the following diagram and table to identify the cables and connectors.

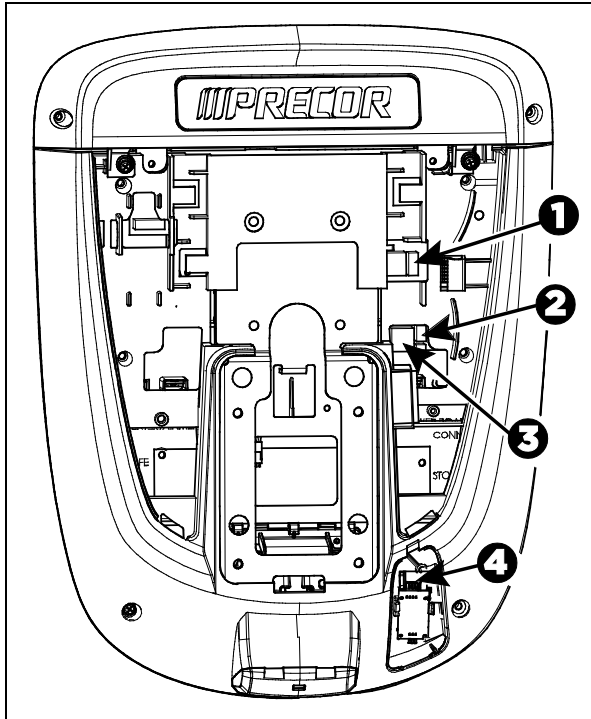

Figure 17: Cable connections, P30 console

Table 2. P30 internal cable connections

Cable	Connector Type	Circuit Connector Location
Safety key (treadmills only)	Six-contact strip, keyed	1
Auto Stop sensor (treadmills only)	Four-contact strip, keyed	2
Data from base unit	Eight-contact modular, on flat gray cable	3
Heart rate sensors	Four-contact strip, keyed	4

Completing the Console Installation (P30)

Before you complete the final installation steps, double-check the connections you have made. Make sure that all cables are fully and securely connected, and that any unneeded cables are tied back properly.

To complete the installation:

1. Feed extra cable back into the neck tube.
2. Tilt the control console backward (toward yourself) until the tab on the top edge of its back plate slides along the top edge of the console mount and the screw holes align properly.
3. Insert the four $\frac{5}{8}$ -inch flat head screws through the holes in the console mount and thread them into the holes in the back plate on the console. Partially tighten the screws using a $\frac{5}{8}$ -inch hex wrench.
4. Line up the two small tabs at the bottom of the console's back cover with the slots at the bottom of the console case. Insert the tabs into the slots.
5. Insert the two #8-32 x $\frac{1}{2}$ -inch Phillips-head screws that you removed earlier into the holes at the top edge of the console's back cover. Tighten the screws fully.
Important: Use caution not to pinch the cables between the back cover and PVS mounting screw heads.
6. Fully tighten the four mounting screws (partially tightened in step 3) using a $\frac{5}{32}$ -inch hex wrench.

Verifying That the Heart Rate Display Is Operational

To verify that the heart rate display is operational:

1. Begin exercising on the equipment.
2. Grasp both touch-sensitive handlebars.
Note: The heart rate is read within ten seconds. During that time, the heart on the display flashes.
3. Look at the HEART RATE display. After a few seconds, a number appears indicating your heart rate.
4. If a number does not appear in the HEART RATE display, check the cable connection to make sure it is properly connected.

Maintenance

To keep the equipment functioning properly, perform the minor maintenance tasks in this section at the intervals shown on the maintenance checklist. Failure to maintain the equipment as described in this section could void the Precor Limited Warranty.

DANGER To reduce the risk of electrical shock, always disconnect the equipment from its power source before cleaning it or performing any maintenance tasks. If the equipment is self-powered but also uses the optional power adapter, disconnect the adapter.

Daily Cleaning

Precor recommends that you clean the equipment before and after each exercise session. To remove dust and dirt from the equipment, wipe all exposed surfaces with a soft cloth that you have moistened with one of the following cleaners:

- A solution of 30 parts of water to 1 part of Simple Green® (for more information, visit www.simplegreen.com)
- ENVIR-O-SAFE oxygen enhanced cleaner or multi-task cleaner concentrate, diluted according to the manufacturer's instructions (for more information, visit www.daleyinternational.com)

Alternatively, you can clean the equipment with Athletix fitness equipment cleaning wipes (for more information, visit www.athletixproducts.com)

CAUTION: Read and follow the manufacturer's instructions, particularly dilution instructions, before using any cleaner on Precor fitness equipment. Do not use concentrated cleaners at full strength, or acidic cleaners of any kind; such cleaners weaken the protective finish on the equipment and void the Precor Limited Warranty. Never pour water or spray liquids onto any part of the equipment. Allow the equipment to dry completely before using.

Vacuum the floor underneath the equipment frequently to prevent the accumulation of dust and dirt that can interfere with its operation. Use a soft nylon scrub brush to clean the grooves on equipment with foot pedals.

Daily Inspection

At least once every day, examine the equipment for the following problems:

- Slipping belts
- Loose fasteners
- Unusual noises
- Worn or frayed power cords
- Any other indication that the equipment may be in need of service

Important: *If you determine that the equipment needs service, disconnect all power connections (television, Ethernet, and power) and move the equipment away from the exercise area. Place an OUT OF SERVICE sign on the equipment and make it clear to all patrons and other users that they must not use it.*

To order parts or to contact a Precor authorized service provider in your area, refer to *Obtaining Service*.

Weekly Maintenance

Perform the following maintenance tasks every week:

1. Disconnect the external power supply.
2. Clean the floor under the equipment using a vacuum cleaner or a damp mop.
3. Verify that the stair-arm bumpers are aligned correctly.
4. When the floor is completely dry, reconnect the power (if necessary).
5. Test all console functions, including heart rate monitoring features.
6. Verify that the unit sits squarely on the floor. All of its feet should be touching the floor and the unit should not rock or wobble when in use. If not, re-level it as described in *Leveling the AMT*.

Monthly Maintenance

Perform the following maintenance tasks every month:

1. Wipe the exterior of the console with a damp sponge or soft cloth, and dry with a clean towel. Keep water away from electronic components to prevent electrical shock or damage.
2. Clean the touchscreen using a soft, lint-free cloth dampened with a 91% isopropyl alcohol solution (either as sold or diluted with an equal amount of water).
3. Remove the access covers. Vacuum out any debris, being careful not to bring the vacuum cleaner nozzle too close to any circuit board (unless your vacuum cleaner is protected against static buildup).
4. Check the belt tension of the primary, brake, and drive belts (refer to the service manual for detailed instructions).
5. Check all fasteners for proper tightness and torque.
6. Replace all covers.
7. Verify that the unit sits squarely on the floor. All of its feet should be touching the floor and the unit should not rock or wobble when in use. If not, re-level it as described in *Leveling the AMT*.

Storing the Chest Strap

If you purchased the optional heart rate chest strap, store it in a place where it remains free of dust and dirt (for example, in a closet or drawer). Be sure to protect the chest strap from extremes in temperature. Do not store it in a place that may be exposed to temperatures below 32° F (0° C).

To clean the chest strap, use a sponge or soft cloth dampened in mild soap and water. Dry the surface thoroughly with a clean towel.

Moving the Equipment

The equipment is very heavy. If you plan to move it to a new location, obtain the help of an adult assistant and use proper lifting techniques. If the equipment includes roller wheels on one end, use the wheels to reduce the load on yourself and your assistant.

To move the AMT:

1. Disconnect, unplug, and remove all external connections (television, Ethernet, and power).
2. Lift the rear platform molding to remove it.
3. Lift the rear foot supports to tip the AMT forward onto its roller wheels.
4. Push the AMT into its new location.
5. Lower the rear foot supports to the floor, then reattach the rear platform molding.

Long-Term Storage

If you do not expect anyone to use the equipment for a long time, perform the following tasks to prepare it for storage:

- If it has a power cord, disconnect the cord.
- If it has an optional power adapter, connect the adapter to prevent damage to the internal battery.
- Position it so that it will not become damaged and will not interfere with people or other equipment.

Self-Powered Features

Important: This chapter of the manual describes Precor fitness equipment that can operate without being connected to AC power. This includes units equipped with P40 or P20 consoles. However, P80 consoles must be connected to AC power through their power supplies to operate. For this reason, this chapter does not apply to units equipped with P80 consoles.

On self-powered equipment, the system initializes and displays the Welcome screen when a user starts exercising. A minimum rate of motion must be maintained for the banner to appear, as shown in the following table. When a person meets the requirements, the power that is generated allows the equipment to function properly.

Table 3. Minimum requirements for operation

Equipment	Rate of Motion
AMT	56 strides per minute (SPM)
EFX	40 strides per minute (SPM)
Climber	30 steps per minute
Bike	20 revolutions per minute (RPM)

Informational displays appear when the battery is low or when the rate of motion drops below the minimum requirements. The display explains what to do to retain power. If the messages are ignored, the equipment begins shutdown procedures to maintain the charge of the battery. Refer to *Informational Displays Prior to Shutdown*.

An optional power adapter can be purchased and provides sustained power to the equipment. If you plan to change the club settings, the power adapter is highly recommended. To purchase the optional power adapter, check with your dealer. Refer to *Obtaining Service*.

Informational Displays Prior to Shutdown

The equipment saves its battery charge by moving into a shutdown mode. If the user does not maintain the minimum rate of motion, a 30-second shutdown process begins.

In this mode, the console displays a countdown indicator and ignores all keypresses. If no movement is detected or the rate of motion remains below the minimum, the indicator changes as the countdown continues.

Note: The user can resume exercising before the countdown period elapses and the program will continue from the point at which it was paused.

Important: *If the equipment is connected to a CSAFE master device, it follows a slightly different shutdown process. Ten seconds before the equipment shuts down, it ends the exercise session and displays a reset message while it disconnects from the CSAFE master device. It ignores all keypresses during these last ten seconds.*

Symptoms of a Low Battery

If no one has used the equipment for an extended period of time, the battery may need recharging.

Symptoms of a low battery include the following:

- A flickering or erratic display
- Loss of user and program information after the user stops exercising, without any display of a workout summary or a notification of pending shutdown

Important: *To maintain a constant power source, use the optional power adapter.*

Using the Optional Power Adapter

After connecting the power adapter to the equipment, plug the opposite end into the appropriate power source (120 V or 240 V).

CAUTION: **When the optional power adapter is in use, make sure that the power supply cord does not create a safety hazard. Keep it out of the way of traffic and moving parts. If the power supply cord or power conversion module is damaged, it must be replaced.**

The control console functions differently when the power adapter is connected. Because the power adapter provides a constant source of power, a user can pause for brief periods without initiating shutdown procedures. When the pause time limit expires and the user has not resumed exercising, the console returns to the Welcome screen. The default pause time is 30 seconds for all fitness equipment. Refer to the manual for your control console for instructions on setting or changing the pause time limit. To learn how to install the power adapter, refer to *The Optional Power Adapter Kit*.

The Optional Power Adapter Kit

If you purchase the optional power adapter, you must also purchase the internal cable kit. The kit supplies the cable, bracket, and fasteners that connect the power adapter to the lower electronics board.

CAUTION: The internal cable kit must be installed by authorized service personnel. Do not attempt installation on your own as you could void the Precor Limited Warranty. For more information, refer to *Obtaining Service*.

Important: *If this equipment includes a P80 console, the optional power adapter and the internal cable kit must still be installed to provide continuous power to the base unit and support its internal battery.*

Once the internal cable kit is installed, you can plug the optional power adapter into the equipment. Plug the opposite end into the appropriate power source for your equipment (120 V or 240 V). Review the safety instructions found at the beginning of this manual before using the power adapter.

Replacing the Battery

The equipment's battery is built to last for a long time. However, if you feel that the battery may need replacing, check with an authorized service technician. Refer to *Obtaining Service*.

CAUTION: The battery stored inside the equipment contains hazardous materials and must be disposed of according to Hazardous Waste Regulations. Refer to *Hazardous Materials and Proper Disposal*.

Commercial Cardiovascular Equipment Limited Warranty

PLEASE READ THESE WARRANTY TERMS AND CONDITIONS CAREFULLY BEFORE USING YOUR PRECOR INCORPORATED PRODUCT. BY USING THE EQUIPMENT, YOU ARE CONSENTING TO BE BOUND BY THE FOLLOWING WARRANTY TERMS AND CONDITIONS.

Limited Warranty.

Precor Incorporated warrants all new Precor products to be free from defects in materials and manufacture for the warranty periods set forth below. The warranty periods commence on the invoice date of the original purchase. This warranty applies only against defects discovered within the warranty period and extends only to the original purchaser of the product. Parts repaired or replaced under the terms of this warranty will be warranted for the remainder of the original warranty period only. To claim under this warranty, the buyer must notify Precor or your authorized Precor dealer within 30 days after the date of discovery of any nonconformity and make the affected product available for inspection by Precor or its service representative. Precor's obligations under this warranty are limited as set forth below.

Warranty Periods and Coverage.

All Commercial Cardiovascular Products (excluding StretchTrainer, Strength Products, and coverage specific to certain models and options as defined below):

- Frame: 7 years
- Treadmill drive motor: 5 years
- Items subject to wear: 1 year
- All other parts (including mechanical parts and electronic parts): 2 years
- Labor: 1 year

880 Line Commercial Cardiovascular Products (superseding the coverage above where applicable):

- Labor on the P80 console: 2 years
- High wear items on the P80 console, including headphone jack, USB connector, and iPod® connector: 90 days

Options / Accessories

Many options or accessories have components that are connected internally or mounted inside the electronic console. The following guidelines determine the warranty for these components. If the internal components are installed by the factory or by an authorized dealer as part of the original sale and delivery, they have a warranty that is identical to the warranty of the equipment in which they are connected or mounted. If the internal components are not installed by the factory or by an authorized dealer as part of the original sale and delivery, they have a 90 days parts and labor limited warranty. All components that are not internally connected have a 90 days parts only limited warranty. Satisfactory proof of purchase is required in all cases.

Conditions and Restrictions.

This warranty is valid only in accordance with the conditions set forth below:

1. The warranty applies to the Precor product only while
 - a. it remains in the possession of the original purchaser and proof of purchase is demonstrated.
 - b. it has not been subjected to accident, misuse, abuse, improper service, or non-Precor modification.
 - c. claims are made within the warranty period.
2. This warranty does not cover damage or equipment failure caused by electrical wiring not in compliance with electrical codes or Precor owner's manual specifications, or failure to provide reasonable and necessary maintenance as outlined in the owner's manual.
3. Precor is not responsible for Internet connectivity to its products. This restriction applies to services, such as those provided by an Internet service provider (ISP), and also to hardware related to Internet connectivity, such as Ethernet cabling, routers, servers and switches.
4. Precor is not responsible for the quality of television, video, audio, or other media supplied to its products. This restriction applies to services, such as those provided by a cable or satellite television provider; to signal strength and clarity; and also to hardware related to the reception and delivery of television, video, audio, and other media. Such hardware can include (but is not limited to) audio, video, and radio-frequency (RF) cabling, connectors, receivers, modulators, combiners, distribution amplifiers, splitters, and so on.
5. Precor cannot guarantee that the heart rate measurement system on its products will work for all users. Heart rate measurement accuracy varies based on a number of factors, including the user's physiology and age, the method in which the heart rate measurement system is used, external interference, and other factors that may influence heart rate acquisition.
6. Except in Canada, Precor does not pay labor outside the United States.
7. Warranties outside the United States and Canada may vary. Please contact your local Dealer for details.

This Limited Warranty shall not apply to:

1. Software version upgrades.
2. Software defects that do not materially and negatively affect the normal performance of the product under normal conditions of use.
3. Consumable goods or cosmetic items of the product, the exterior of which has been damaged or defaced as a result of abuse, misuse, accident, improper service or installation, mishandling, or modification in design or construction not authorized by Precor.
4. Repairs performed on Precor equipment missing a serial number or with a serial tag that has been altered or defaced.
5. Service calls to correct installation of the equipment or instruct owners on how to use the equipment.
6. Pickup and delivery involved with repairs.
7. Any labor costs incurred beyond the applicable labor warranty period.

Disclaimer and Release.

The warranties provided herein are the exclusive warranties given by Precor and supersede any prior, contrary or additional representations, whether oral or written. ANY IMPLIED WARRANTIES, INCLUDING THE WARRANTY OF MERCHANTABILITY OR FITNESS FOR A PARTICULAR PURPOSE THAT APPLY TO ANY PARTS DESCRIBED ABOVE ARE LIMITED IN DURATION TO THE PERIODS OF EXPRESS WARRANTIES GIVEN ABOVE FOR THOSE SAME PARTS. PRECOR HEREBY DISCLAIMS AND EXCLUDES THOSE WARRANTIES THEREAFTER. Some States do not allow limitations on how long an implied warranty lasts, so the above limitation may not apply to you. PRECOR ALSO HEREBY DISCLAIMS AND EXCLUDES ALL OTHER OBLIGATIONS OR LIABILITIES, EXPRESS OR IMPLIED, ARISING BY LAW OR OTHERWISE, WITH RESPECT TO ANY NONCONFORMANCE OR DEFECT IN ANY PRODUCT, INCLUDING BUT NOT LIMITED TO: (A) ANY OBLIGATION, LIABILITY, RIGHT, CLAIM OR REMEDY IN TORT, WHETHER OR NOT ARISING FROM THE NEGLIGENCE OF PRECOR OR ITS SUPPLIERS (WHETHER ACTIVE, PASSIVE OR IMPUTED); AND (B) ANY OBLIGATION, LIABILITY, RIGHT, CLAIM OR REMEDY FOR LOSS OF OR DAMAGE TO ANY EQUIPMENT. This disclaimer and release shall apply even if the express warranty set forth above fails of its essential purpose.

Exclusive Remedies.

For any product described above that fails to conform to its warranty, Precor will provide, at their option, one of the following: (1) repair; (2) replacement; or (3) refund of the purchase price. Precor Limited Warranty service may be obtained by contacting the authorized dealer from whom you purchased the item. Precor compensates Servicers for warranty trips within their normal service area to repair commercial equipment at the customer's location. You may be charged a trip charge outside the service area. THESE SHALL BE THE SOLE AND EXCLUSIVE REMEDIES OF THE BUYER FOR ANY BREACH OF WARRANTY.

EXCLUSION OF CONSEQUENTIAL AND INCIDENTAL DAMAGES.

PRECOR AND/OR ITS SUPPLIERS SHALL HAVE NO OBLIGATION OR LIABILITY, WHETHER ARISING IN CONTRACT (INCLUDING WARRANTY), TORT (INCLUDING ACTIVE, PASSIVE, OR IMPUTED NEGLIGENCE AND STRICT LIABILITY), OR OTHERWISE, FOR DAMAGE TO THE EQUIPMENT, PROPERTY DAMAGE, LOSS OF USE, REVENUE OR PROFIT, COST OF CAPITAL, COST OF SUBSTITUTE EQUIPMENT, ADDITIONAL COSTS INCURRED BY BUYER (BY WAY OF CORRECTION OR OTHERWISE) OR ANY OTHER INCIDENTAL, SPECIAL, INDIRECT, OR CONSEQUENTIAL DAMAGES, WHETHER RESULTING FROM NONDELIVERY OR FROM THE USE, MISUSE OR INABILITY TO USE THE PRODUCT. This exclusion applies even if the above warranty fails of its essential purposes and regardless of whether such damages are sought for breach of warranty, breach of contract, negligence, or strict liability in tort or under any other legal theory. Some states do not allow the exclusion or limitation of incidental or consequential damages, so the above limitation may not apply to you.

This warranty gives you specific legal rights, and you may also have other rights, which vary from state to state.

Complete this portion and keep for your records.

Purchased From: _____
Example: Dealer or store name.

Phone Number: _____
Example: Dealer or store telephone number.

Product/model: _____
Example: AMT 885 or EFX 883.

Serial number: _____
The serial number is found on the shipping container.

Effective 1 November 2010
P/N 36286-114



Precor Incorporated
20031 142nd Avenue NE
P.O. Box 7202
Woodinville, WA USA 98072-4002

AMT 885/835 PAG/OM 300710-301 rev F
Warranty #36286-114
14 February 2011

Operating and Maintaining the P30 Console



Operating and Maintaining the P30 Console

PRECOR®

Edition Information

Operating and Maintaining the P30 Console

P/N 301096-141

Copyright ©2011 Precor Incorporated. All rights reserved.
Specifications subject to change without notice.

Trademark Note

Precor, AMT, and EFX are registered trademarks and Preva is a trademark of Precor Incorporated. Other names in this document may be the trademarks or registered trademarks of their respective owners.

Intellectual Property Notice

All rights, title, and interests in and to the software of the Preva Business Suite, the accompanying printed materials, any copies of such software, and all data collected via the Preva Business Suite, are exclusively owned by Precor or its suppliers, as the case may be.

Precor is widely recognized for its innovative, award-winning designs of exercise equipment. Precor aggressively seeks U.S. and foreign patents for both the mechanical construction and the visual aspects of its product design. Any party contemplating the use of Precor product designs is hereby forewarned that Precor considers the unauthorized appropriation of its proprietary rights to be a very serious matter. Precor will vigorously pursue all unauthorized appropriation of its proprietary rights.

Precor Incorporated
20031 142nd Ave NE, P.O. Box 7202
Woodinville, WA 98072-4002
1-800-347-4404

<http://www.precor.com>

Important Safety Instructions

This apparatus (hereinafter referred to as the console) is intended to be shipped with a new Precor exercise equipment (hereinafter referred to as the base unit). It is not packaged for individual sale.

WARNING To prevent injury, the console must be attached securely to the base unit following all assembly and installation instructions shipped with the base unit. The console is intended to be connected to AC mains power through the furnished power supply ONLY. It should be powered on only when installed as described in the assembly and installation instructions shipped with the base unit. The console is intended for use only with a Precor fitness equipment, not as a standalone device.

Safety Precautions

Always follow basic safety precautions when using this equipment to reduce the chance of injury, fire, or damage. Other sections in this manual provide more details of safety features. Be sure to read these sections and observe all safety notices. These precautions include the following:

- Read all instructions in this guide before installing and using the equipment and follow any labels on the equipment.
- Make sure all users see a physician for a complete physical examination before they begin any fitness program.
- *Il est conseillé de subir un examen médical complet avant d'entreprendre tout programme d'exercice. Si vous avez des étourdissements ou des faiblesses, arrêtez les exercices immédiatement.*

- Do not allow children, or people unfamiliar with the operation of this equipment, on or near it. Do not leave children unsupervised around the equipment.
- Make sure all users wear proper exercise clothing and shoes for their workouts and avoid loose or dangling clothing. Users should not wear shoes with heels or leather soles, and they should check the soles of their shoes to remove any dirt and embedded stones. They should also tie long hair back.
- Never leave the equipment unattended when it is plugged in. Unplug the equipment from its power source when it is not in use, before cleaning it, and before providing authorized service.

Note: The optional power adapter is considered a power source for self-powered equipment.

- Use the power adapter provided with the equipment. Plug the power adapter into an appropriate, grounded power outlet as marked on the equipment.
- Care should be taken when mounting or dismounting the equipment.
- Read, understand, and test the emergency stop procedures before use.
- Keep the power cord or optional power adapter and plug away from heated surfaces.
- Route power cables so that they are not walked on, pinched, or damaged by items placed upon or against them, including the equipment itself.
- Ensure the equipment has adequate ventilation. Do not place anything on top of or over the equipment. Do not use on a cushioned surface that could block the ventilation opening.
- Assemble and operate the equipment on a solid, level surface.
- Keep equipment away from water and moisture. Avoid dropping anything on or spilling anything inside the equipment to prevent electric shock or damage to the electronics.
- Do not operate electrically powered equipment in damp or wet locations.
- Never operate this equipment if it has a damaged cord or plug, if it is not working properly, or if it has been dropped, damaged, or exposed to water. Call for service immediately if any of these conditions exist.

- Proper Location for Equipment
 - For all equipment other than treadmills: Locate at least 40 inches (1 meter) away from walls or furniture on either side of the equipment, and 40 inches (1 meter) away from objects behind the equipment.
 - For treadmills: Locate at least 40 inches (1 meter) away from walls or furniture on either side of the treadmill, and at least 80 inches (2 meters) away from objects behind the treadmill.

Important: These location standards should also be used when positioning equipment away from sources of heat, such as radiators, heat registers, and stoves. Avoid temperature extremes.

- Maintain the equipment to keep it in good working condition, as described in the *Maintenance* section of the assembly and maintenance guide. Inspect the equipment for incorrect, worn, or loose components, and then correct, replace or tighten prior to use.
- If you plan to move the equipment, obtain help and use proper lifting techniques.
- Equipment Weight Restrictions: Do not use the treadmill if you weigh more than 500 pounds (225 kg). If you weigh more than 350 pounds (160 kg), do not run on the treadmill. For all other fitness equipment, the weight limit is 350 pounds (160 kg).
- Use the equipment only for its intended purpose as described in this manual. Do not use accessory attachments that are not recommended by Precor. Such attachments may cause injuries.
- Do not operate the equipment where aerosol (spray) products are being used or where oxygen is being administered.
- Do not use outdoors.
- Do not attempt to service the equipment yourself, except to follow the maintenance instructions in this manual.
- Never drop or insert objects into any opening. Keep hands away from moving parts.
- Do not set anything on the stationary handrails, handlebars, control console, or covers. Place liquids, magazines, and books in the appropriate receptacles.
- Do not lean on or pull on the console at any time.

- When using the treadmill, always attach the safety clip to your clothing before beginning your workout. Failure to use the safety clip may pose a greater risk of injury in the event of a fall.

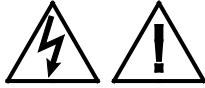

CAUTION: DO NOT remove the cover, or you may risk injury due to electric shock. Read the assembly and maintenance guide before operating. There are no user-serviceable parts inside. Contact Customer Support if the equipment needs servicing. For use with single phase AC supply only.

Hazardous Materials and Proper Disposal

The batteries within self-powered equipment contain materials that are considered hazardous to the environment. Federal law requires proper disposal of these batteries.

If you plan to dispose of your equipment, contact Precor Commercial Products Customer Support for information regarding battery removal. Refer to *Obtaining Service*.

Product Recycling and Disposal

This equipment must be recycled or discarded according to applicable local and national regulations.

Product labels, in accordance with European Directive 2002/96/EC concerning waste electrical and electronic equipment (WEEE), determine the framework for the return and recycling of used equipment as applicable throughout the European Union. The WEEE label indicates that the product is not to be thrown away, but rather reclaimed upon end of life per this Directive.

In accordance with the European WEEE Directive, electrical and electronic equipment (EEE) is to be collected separately and to be reused, recycled, or recovered at end of life. Users of EEE with the WEEE label per Annex IV of the WEEE Directive must not dispose of end of life EEE as unsorted municipal waste, but use the collection framework available to customers for the return, recycling, and recovery of WEEE. Customer participation is important to minimize any potential effects of EEE on the environment and human health due to the potential presence of hazardous substances in EEE. For proper collection and treatment, refer to *Obtaining Service*.

Regulatory Notices for Cardiovascular Exercise Equipment

The regulatory information in this section applies to the exercise equipment and its control console.

Safety Approvals for Cardiovascular Equipment

Precor equipment has been tested and found to comply with the following applicable safety standards.

Cardiovascular Type Equipment:

- CAN/CSA, IEC, EN 60335-1 (Household and similar electrical appliances - Safety)
- EN 957 (Stationary training equipment, class S/B compliant equipment)

Radio Frequency Interference (RFI)

This Precor exercise equipment conforms to the following national standards defining acceptable limits for radio frequency interference (RFI).

Federal Communications Commission, Part 15

This equipment has been tested and found to comply with the limits for a Class A digital device, pursuant to Part 15 of the FCC Rules. These limits are designed to provide reasonable protection against harmful interference in a commercial installation. The equipment generates, uses, and can radiate radio frequency energy and, if not installed and used in accordance with the owner's manual instructions, can cause harmful interference to radio communications.

Operation is subject to the following two conditions: (1) this device may not cause harmful interference, and (2) this device must accept any interference received, including interference that may cause undesired operation.

WARNING Per FCC rules, changes or modifications not expressly approved by the manufacturer could void the user's authority to operate the equipment.

Industry Canada

This device complies with RSS-210:2007 of the Spectrum Management & Telecommunications Radio Standards Specification. Operation is subject to the following two conditions: (1) this device may not cause harmful interference, and (2) this device must accept any interference received, including interference that may cause undesired operation.

This Class A digital apparatus complies with Canadian ICES-003.

Cet appareil numérique de la classe A est conforme à la norme NMB-003 du Canada.

ATTENTION: Haute Tension
Débranchez avant de réparer

European Applications

CE compliance is claimed to the following directives:

- 2004/108/EC EMC Directive
- 2006/95/EC LVD Directive
- 2002/95/EC RoHS Directive

Directive compliance has been verified to the following standards:

- EN 55022
- EN 55024
- EN 60335-1

120 V and 240 V Equipment Designated for U.S. Markets

Note: If you are not installing this equipment in the United States or Canada, this section does not apply to you. You should have received a power cable that meets your local electrical code requirements along with the equipment. If you need additional help with the power connections for the equipment, contact your Precor authorized dealer.

Precor exercise equipment that is connected to an external power circuit, such as treadmills or equipment with optional power supplies for self-powered equipment, must be properly grounded. In addition, Precor treadmills must be connected to a 20 amp, dedicated branch circuit for power.

Important: A true dedicated branch circuit provides discrete hot, neutral, and ground lines to each plug. These lines must not be looped or "daisy-chained" to any other lines in any way.

For non-powered equipment fitted a Personal Viewing System (PVS) screens, up to 10 consoles or PVS screens can be connected to a single 20 amp dedicated branch circuit, or up to 7 consoles to a single 15 amp dedicated branch circuit.

The grounding plug on a treadmill or power supply looks like the plug shown in one of the following two figures. The power outlet must have the same configuration as the plug.

Important: Do not use any power cord adapter with this product.

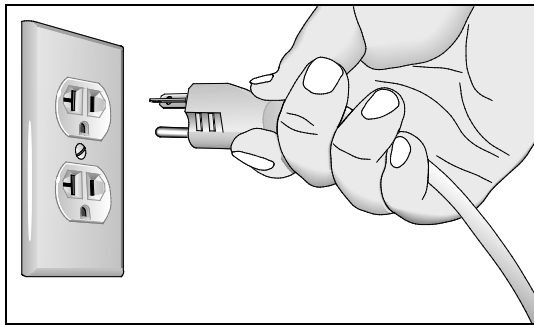

Figure 1: 120-volt, 20-amp power plug

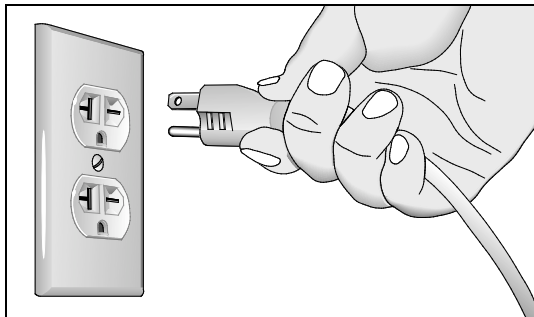

Figure 2: 240-volt, 20-amp power plug

Obtaining Service

Do not attempt to service the equipment except for maintenance tasks. If any items are missing, contact your dealer. For more information regarding customer support numbers or a list of Precor authorized service centers, visit the Precor web site at <http://www.precor.com>.

For the most current manuals, go to <http://www.precor.com/productmanuals>.

Table of Contents

Important Safety Instructions	3
Safety Precautions.....	3
Hazardous Materials and Proper Disposal.....	6
Product Recycling and Disposal	6
Regulatory Notices for Cardiovascular Exercise Equipment	7
120 V and 240 V Equipment Designated for U.S. Markets.....	8
Obtaining Service.....	9
Getting Started	13
Activating the Console for Self-Powered Equipment	13
Identifying Parts of the Console.....	15
Setting Up the Console	19
System Settings.....	19
Setting Club Parameter Values.....	21
Viewing the Informational Displays	26
User ID Entry with CSAFE Equipment.....	29
Introducing Users to the P30 Console.....	31
Using the Touch Heart Rate Feature	31
Using a Chest Strap Transmitter	33
Using the Treadmill Safety Clip	34
Treadmill Auto Stop™ (Automatic Stop) Function.....	36
Starting a Workout	37
Starting a Preset Programmed Workout.....	38
Setting Options.....	38
Pausing and Resuming an Exercise Session	40
Ending a Session.....	41
Programs	43
Maintenance	45
Cleaning the Console and Display	45

Getting Started

The P30 console offers administrators the ability to set default values that meet their specific needs. These settings include items like language, units of measure, and setting a maximum allowed workout time for each piece of equipment.

Activating the Console for Self-Powered Equipment

Precor equipment is either self-powered or externally powered using an optional power adapter. Self-powered equipment requires the user exercise to initialize the battery. This section provides more detail about powering equipment.

Activating the Console for Self-Powered Equipment

On self-powered equipment, when a user starts exercising, the battery initializes and displays the Welcome banner. A minimum rate of motion must be maintained for the Welcome banner to appear. The words PEDAL FASTER (or the equivalent message depending on the equipment type) appear in the display when the battery is low or when the rate of motion drops below the minimum requirements.

The equipment saves its battery charge by moving into a shutdown mode. If the user does not maintain the minimum rate of motion, a 30-second shutdown process begins.

In this mode, the console displays a countdown indicator and ignores all keypresses. If no movement is detected or the rate of motion remains below the minimum, the indicator changes as the countdown continues.

Note: The user can resume exercising before the countdown period elapses and the program will continue from the point at which it was paused.

Optional Use of the Power Adapter

An optional AC power adapter provides sustained power to the equipment. This adapter allows you to change settings without having to pedal the equipment. To purchase the power adapter, contact your dealer.

If you purchase the optional power adapter, you must also purchase the internal cable kit. The kit supplies the cable, bracket, and fasteners that connect the power adapter to the lower electronics board.

CAUTION: The internal cable kit must be installed by authorized service personnel. Do not attempt installation on your own as you could void the Precor Limited Warranty. For more information, refer to *Obtaining Service*.

Once the internal cable kit is installed, you can plug the optional power adapter into the equipment. Plug the opposite end into the appropriate power source for your equipment (120 V or 240 V). Review the safety instructions found at the beginning of this manual before using the power adapter.

CAUTION: When the optional power adapter is in use, make sure that the power supply cord does not create a safety hazard. Keep it out of the way of traffic and moving parts. If the power supply cord or power conversion module is damaged, it must be replaced.

The control console functions differently when the power adapter is connected. Because the power adapter provides a constant source of power, a user can pause for brief periods without initiating shutdown procedures. When the pause time limit expires and the user has not resumed exercising, the console returns to the Welcome screen. The default pause time is 30 seconds for all fitness equipment. Refer to the manual for your control console for instructions on setting or changing the pause time limit.

Identifying Parts of the Console

The following diagram provides information about the console keys. The number and actions of the console keys may differ slightly depending on the type of equipment.

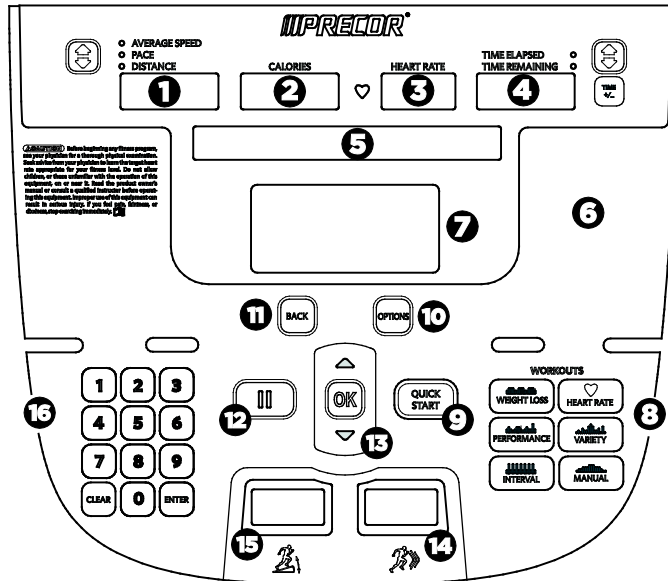

Figure 3: P30 console keys

Table 1. Parts of the console

Number	Part Name	Details
1	Average Speed Pace Distance	Use the ▲ or ▼ arrows to change which item you want to display
2	Calories	Displays the number of calories you have burned
3	Heart Rate	Displays your heart rate
4	Time Elapsed Time Remaining	Use the ▲ or ▼ arrows to change how the time is displayed
5	Upper Text Display	Scrolls information to guide the user

Number	Part Name	Details
6	<ul style="list-style-type: none"> • Muscle Monitor - EFX • Stride Length - AMT • Rate per Minute - Climber • <blank> - Bike, Treadmill 	<ul style="list-style-type: none"> • The Muscle Monitor displays the muscles used to perform that workout. • Stride Length describes the length of your steps during a workout. • Rate per Minute displays the number of meters, feet, or steps that a user has gained during a workout.
7	Lower Display	Displays graphical information about your workout progress
8	Workouts	<ul style="list-style-type: none"> • Manual: Available on all equipment • Heart Rate: Available on all equipment • Interval: Available on all equipment • Weight Loss: Available on all equipment except AMT • Variety: Available on all equipment except AMT • Performance: Available on all equipment except AMT • Fat Burner - AMT only
9	Quick Start	Press to begin exercising

Number	Part Name	Details
10	Options - All equipment except AMT	<ul style="list-style-type: none"> • Press to enter Goals, Language, Weight, Age, and Target Heart Rate information, More Options • Press More Metrics to view additional metric information for all equipment except the AMT <p>Metrics:</p> <ul style="list-style-type: none"> • Percent Complete • Time in Zone • Segment Time Remaining • Average Speed • Pace - Treadmill only • Calories per Minute • Calories per Hour • WATTS • METS • Target HR • Average HR • Elevations - Treadmill and climber only • Stride Length - AMT only • Show All
10	Metrics key-AMT only	<ul style="list-style-type: none"> • Use to view Metric information on AMT
11	Back	Returns user to the previous screen
12	Pause	Use to momentarily stop machine during a workout
13	OK and Up/Down arrows	Used to navigate options and settings
14	Speed or Intensity Indicator	AMT, bike, treadmill, EFX (single), and EFX (dual)
15	Incline or Resistance Indicator	Treadmill, EFX (dual), and climber

Number	Part Name	Details
16	Number pad	Use to enter numerical information such as age, weight, and passwords. Press Clear to delete the numbers entered. Press Enter after you have entered numbers on this number pad.

Setting Up the Console

Use the System Settings mode to configure settings in a way that benefits your users and your facility. The System Settings menu is visible only to administrators and registered service technicians. Changes made to these settings are saved to the fitness equipment.

The System Settings categories are:

- Club Settings
- Informational Display

System Settings

System Setting features remain hidden from club patrons and can only be accessed using special keypresses. To view the System Settings, the equipment must be in the Welcome state and display the Welcome banner. To access the Welcome banner, you must power the equipment. For self-powered equipment, use the optional power adapter, otherwise you will have to maintain the minimum rate of motion. For more information on self-powered equipment, refer to *Activating the Console for Self-Powered Equipment*.

The equipment is in the Welcome state when it is on, but not actually in use. This means that there is no exercise session, data entry, or diagnostic operation in progress.

When the equipment is in the Welcome state:

- **PRECOR** scrolls on the lower text display. **SELECT A WORKOUT OR PRESS QUICKSTART TO BEGIN** scrolls in the upper text display.
- The heart rate signal is the only segment activated.
- On the treadmill, the belt is not moving and the lift motor is off.

Note: On self-powered equipment, the battery initializes when you begin working out. You must maintain a minimum rate of motion for the Welcome banner to appear.

The changes made in System Setting modes become the default settings when the display resets to the Welcome banner.

CAUTION: If you change the Unit of Measure display on the treadmill, check the speed setting to verify that it is correct.

To view the Club Parameters settings:

1. At the Welcome banner, press **Pause**.



2. Press the following number keys in sequence to enter the password:
5 6 5 1 5 6 5
3. Press **OK**.
The Set Club Parameters banner appears.

Table 2. Navigational keys for the system setting modes

Key	Function
▲ or ▼	Guides you through the settings menu and selections.
OK	Select a menu selection.
BACK	Returns to the previous menu level without saving changes.
PAUSE	Exits the System Settings mode and returns to the Welcome banner.

Setting Club Parameter Values

Use this information to customize the equipment for your setting.

Safety Code (Treadmill only)

Value Range: Enabled or Disabled

(Default: Disabled)

When the equipment is shipped from the factory, the safety code protection feature is disabled. If you enable the safety code, your users will need to enter a four digit number to begin their exercise session and start the running belt.

Select Language (All Equipment)

Value Range: English, Deutsch, Espanol, Francais, Netherlands, Portugues, Rucckijj, and Italiano

(Default: English)

Select your preferred language for the console display.

Note: Programming prompts are not affected by language selection. The prompts in this section continue to appear in English.

Set Units (All Equipment)

Value Range: U.S. or Metric

(Default: U.S.)

The equipment can display measurements in either Metric or U.S. Standard.

Important: *If you change the Unit of Measure on a treadmill, be sure to check the speed setting to verify that it is correct.*

Set Max Workout Time (All Equipment)

Value Range: 1 to 240 minutes

(Default: 60 minutes)

You can set a maximum workout time per session. Choose a time limit between 1 and 240 minutes, or select **No Limit** if you do not want to set a time limit. For example, if you set the time limit to 20 minutes, users can only enter a workout time between 1 and 20 minutes.

Select No Limit if you do not want to set a time limit.

Note: The Military Performance Programs will not complete if the maximum exercise time limit is less than 40 minutes. Set the maximum time about 40 minutes if you have enabled these performance programs.

Set Max Pause Time (All Equipment)

Value Range: 1 to 120 seconds

(Default: 120 seconds)

This setting limits how long equipment remains in a paused banner during a workout before it resets.

Note: The optional power adapter must be connected on self-powered equipment to establish a definitive pause time limit. If the optional power adapter is not attached and the rate of motion drops below the minimum requirements, the equipment begins its 30-second shutdown, effectively eliminating pause mode

Set Cool Down Time (All Equipment)

Value Range: 0 to 5 minutes

(Default: 5 minutes)

Select the maximum amount of time the equipment remains in the cool down mode. The cool down time is the period of time following the completion of a program when the user exercises at a reduced work rate.

Creating a Custom Workout

Value Range: ON or OFF

(Default Value: OFF)

Create a customized program for your workout.

Note: This option is not available on all equipment.

To create a custom program:

1. At the **SET CUSTOM PROGRAM** prompt, press **OK**.
The program profile appears in the display and a blinking column indicates your starting point.
2. Press the down arrow key on the navigational keypad, to select the column you want to change.
3. To change the height of the column, refer to the following table.

Table 3. Custom Program keys

Equipment	Key Name	Description
Treadmill	INCLINE	Changes the column height and affects the Custom Program incline.
EFX (835 only)	INCLINE	Changes the column height and affects the Custom Program ramp incline.
Bike	RESISTANCE	Changes the column height and affects the Custom Program pedal resistance.
Climber	RESISTANCE	Changes the height of the column and affects the Custom Program step resistance.

4. When you have set the column height, press the down arrow key on the navigational keypad to move to the next column. You can press the up arrow key to return to previous columns.
5. Continue adjusting the profile for each column.

Note: Two custom programs are available on the treadmill. Some Precor products contain only one custom program. The prompt indicates which one you have accessed. To select a second custom program (treadmill only), press the down arrow key on the navigational keypad, before pressing OK in step 6.

The Set Custom Program 2 default value is **Disabled**.

6. When you have finished creating your program, press **OK** to save the program profile, and return to the Welcome banner. Press **BACK**, to exit this setting without saving your changes to the custom profile.

Set Speed Limit (Treadmill only)

Value Range: Full speed range of equipment

(Default: Maximum speed)

This setting limits how fast the running belt moves and, consequently, the number of speed settings that are available to the user. Use it to set the maximum speed that a user can enter when using the equipment.

The speed is displayed in miles per hour (mph) or kilometers per hour (kph) depending upon the units of measure (U.S. Standard or Metric) selected earlier. The speed ranges values from 0.5 to 16 mph (0.8 to 25.5 kph).

Set Incline Limit (Treadmill only)

Value Range: Full grade range of equipment

(Default: Maximum grade possible)

Set the maximum percent incline that a user can enter when using the equipment.

Hidden Programs (Treadmill only)

Value Range: Show Programs or Hide Programs

(Default: Hide Programs)

When set to Show Programs, all Performance Programs are available to a user through the PERFORMANCE key. These programs are: Gerkin Fitness Test, USAF PRT, NAVY PRT, ARMY PFT, USMC PFT, and Federal Law Enf. PEB.

If set to **HIDE PROGRAMS**, when the user presses **PERFORMANCE**, the message **WORKOUT NOT AVAILABLE** will scroll in the upper text display.

Set Resistance Range (Bike only)

Value Range: High, Medium, or Low

(Default: High)

You can set a low, medium, or high base resistance on the recumbent or upright bikes. There are 25 levels of resistance within each base setting, but the base setting affects the overall resistance range. The following ranges are available:

- High: Provides full resistance range
- Medium: Provides approximately two thirds of the resistance that is available within the high group setting.
- Low: Provides approximately one third of the resistance that is available within the high group setting.

Set Crossramp Auto Level (EFX Dual only)

Value Range: 0 to 20

(Default: 10)

Use this setting to choose a specific ramp incline so that the EFX automatically returns to that incline at the end of a workout session.

Viewing the Informational Displays

Information Display settings are values that provide you with information about the equipment. Types of information contained in this setting group include, an event log, software and equipment serial numbers, and usage information.

To view the System settings:

1. At the Welcome banner, press **Pause**.



2. Press the following number keys in sequence to enter the password:

6 5

3. Press **Enter**.

Use the following table to set up customized Informational Display values.

Table 4. Informational Displays values

Product	Value	Information provided
All	ODOMETER	<p>The odometer value correlates to the type of equipment and the standard of units, U.S. or Metric, selected in the programs.</p> <ul style="list-style-type: none"> • Treadmill: Displays the number of cumulative miles or kilometers logged to date. • EFX or AMT: Displays the number of total strides logged to date. • Bike: Displays the number of total revolutions logged to date. • Climber: Displays the number of floors climbed.
All	HOUR METER	<ul style="list-style-type: none"> • Displays the number of hours that the equipment has been in use. • The equipment tracks the elapsed minutes, but the value that appears is truncated to the nearest full hour.
All	UPPER BOOT SW PART NUMBER	Upper board application software part number and version

Product	Value	Information provided
All	UPPER BASE SW PART NUMBER	Upper base application software version
All	LOWER BASE SW PART NUMBER	Lower application software version
All	METRICS BOARD	Software number on the Metrics Board
AMT	STRIDE DIAL SW PART NUMBER	Stride Dial software number
All	SERIAL NUMBER	Used to determine exact model and type of equipment
All	USAGE LOG	<ul style="list-style-type: none"> The number of times each program has been used and displays the associated cumulative minutes. Helpful in determining user preferences in program selection.
All	EVENT LOG	Displays any event codes that may have been detected by the software. For more information, refer to <i>Event Log</i> .

Event Log

The event log holds a maximum of 30 events. After the log reaches 30 events, older events are erased to make room for newer ones.

Each event log entry contains the following information:

- Event number
- Odometer value when the event occurred
- Hour meter value at the time the event occurred
- Current drawn by the motor when the event occurred (treadmill only)

The following table contains a list of events detectable by the software.

Table 5. Event log numbers and descriptions

Event Number	Description of Event
00	Upper PCA memory location event
02	RAM location event
03	EEPROM checksum event
05	Depressed key at power up

Event Number	Description of Event
09	Lower PCA memory test event
10	Line Frequency out of acceptable range
11	Watchdog (Upper PCA) low voltage power
12	Watchdog (Lower PCA) low voltage power
13	Fan at incorrect speed (version 1 treadmills)
14	Fan fail (lower PCA)
15	AC input voltage too high
16	AC input voltage too low
20	Too many maximum power requests in one second
21	Too many maximum consecutive power requests
22	No motor pulses at start up
23	Motor pulses missing after start up
24	Reduce speed requested, speed is not reducing
26	Motor pulse width incorrect
27	Too much drive motor current
28	Temperature too high
29	Excessive AC input current
30	Communications event lower board to upper board
31	Incorrect Communications event upper board to lower board
32	Communication event upper board to lower board
33	Incorrect communications event lower board to upper board
40	Lift motion detected
42	Lift position value out of range
43	Zero switch not found
44	Un-commanded lift motion
45	Lift going in the wrong direction
50	Too much brake (magnet) current
53	Cannot read target, cannot find home switch
54	Target pulses lost during operation
55	Brake home switch activated unexpectedly
60	Auto Stop sensor failure (treadmill)
61	Auto Stop not present (treadmill)

User ID Entry with CSAFE Equipment

This equipment is fully compatible with CSAFE protocols. When the equipment is connected to a CSAFE master device, the user is prompted to press ENTER and begin an identification process. The user ID is displayed as five zeros and indicates the starting point. The following table describes key functions while in CSAFE mode.

Table 6. CSAFE access keys

Keys	Function
Number Keypad	Use the number keys to enter a user ID. Once you have entered the user ID number, press ENTER or OK to submit the user ID.
CLEAR	Erases individual numbers in the user ID from right to left.
ENTER or OK	Submits the user ID. Note: User ID entry is bypassed when the user enters five zeros. No workout statistics are recorded.
PAUSE	Resets to the Welcome banner.

A message appears on the display and indicates when the user ID is accepted by the CSAFE master device. Once program selection is complete, the user can begin exercising.

Introducing Users to the P30 Console

CAUTION: Before beginning any fitness program, see your physician for a thorough physical examination. Seek advice from your physician to learn the target heart rate appropriate for your fitness level.

The P30 console offers an easy-to-follow display and multiple programs to help people meet their exercise needs.

Important: Please review the following sections in this guide with your users before allowing them to use the fitness equipment:

- *Important Safety Instructions*
- *Getting Started*
- *Using the Safety Clip (for treadmill only)*

Using the Touch Heart Rate Feature

Note: Touch heart rate performance may vary based on a user's physiology, fitness level, age, and other factors. You may experience an erratic readout if your hands are dry, dirty, or oily, or if the skin on your palms is especially thick. Wearing hand lotion can also cause an erratic readout. In addition, make sure that the sensors are clean to ensure proper contact can be maintained.

To use the touch heart rate feature, place the palm of your hands directly on the metal heart rate sensors on the equipment's handlebars. To ensure a more accurate heart rate readout, make sure you follow these tips:

- Both hands must grip the sensors for your heart rate to register.
- It takes a number of consecutive heart beats (15-20 seconds) for your heart rate to register.
- When gripping the sensors, do not grip tightly. Keep a loose, cupping hold. Holding the grips tightly can affect the reading.
- As you work out, your perspiration will help transmit your heart rate signal. If you have difficulty using the handheld grips to determine your heart rate, try the sensors again later in the workout to see if you can obtain a heart rate signal.
- If the touch heart rate feature does not work for you, Precor recommends that you use a chest transmitter strap.

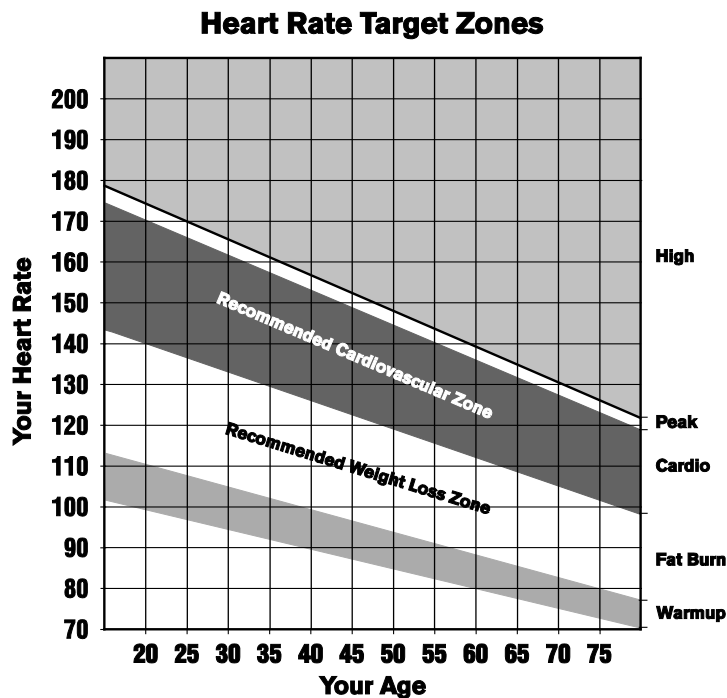

Figure 4: Heart rate target zones

CAUTION: Your heart rate should never exceed 85% of your maximum aerobic heart rate. Your maximum heart rate is equal to 220 minus your age.

Using a Chest Strap Transmitter

WARNING Signals used by the heart rate straps may interfere with pacemakers or other implanted devices. Consult your physician and the manufacturers of your heart rate strap and implanted device before using a heart rate strap.

Wearing a chest strap transmitter during your workout provides steady heart rate information. For the equipment to detect your heart rate, you must grip the touch heart rate sensors or wear a chest strap transmitter while exercising. In the presence of both touch and wireless data, the touch data takes precedence and will display.

Note: To receive an accurate reading, the strap needs to be in direct contact with the skin on the lower sternum (just below the bust line for women).

To use a chest strap transmitter:

1. Carefully dampen the back of the strap with tap water.
Important: Do not use deionized water. It does not have the proper minerals and salts to conduct electrical impulses.
2. Adjust the strap and fasten it around your chest. The strap should feel snug, not restrictive.
3. Make sure that the chest strap is right-side-up, lies horizontally across, and is centered in the middle of your chest.
4. Test the chest strap placement by checking the heart rate function on the equipment. If a heart rate is registering, your chest strap placement is correct. If the equipment does not register a heart rate, readjust the strap and recheck the heart rate function.

Using the Treadmill Safety Clip

The treadmill is equipped with two different stop functions, which behave as follows:

<i>If the user ...</i>	<i>Then the treadmill belt ...</i>	<i>And the console ...</i>
Presses down on the red STOP button 2	Slows to a stop	Shows that the exercise workout is paused
Pulls on the lanyard attached to the safety clip and trips the restart switch 1	Slows to a stop	Shows the words PUSH TO RESET SWITCH and an arrow pointing to the Restart switch

The restart switch is located just below the console and immediately behind the red **STOP** button, as shown in the following illustration. When it is tripped, the bar pops up, displaying the words **PUSH TO RESET SWITCH** on its front side. The treadmill does not operate while these words are visible.

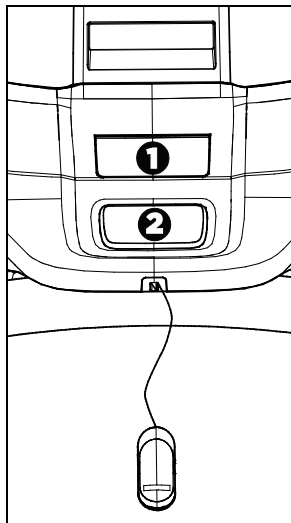

Figure 5: Restart switch

Instruct users on how important it is to use the safety clip while exercising on the treadmill, and demonstrate how they should attach it to their clothing near the waistline.

If the restart switch trips during exercise, perform the following steps:

1. Reattach the safety clip if necessary.
2. Press the restart switch down until it clicks, returning it to its normal position.

Note: If the restart switch trips, all information about the current workout is deleted.

3. Start the workout from the beginning, reducing the time as needed to account for the amount of exercise that has been completed.

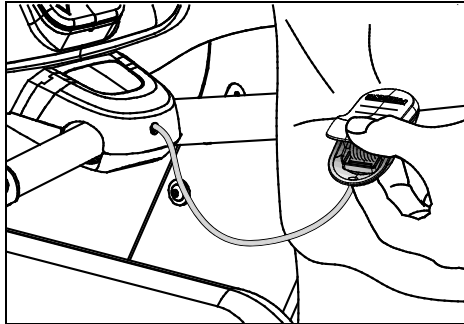

Figure 6: Attaching the safety clip

Treadmill Auto Stop™ (Automatic Stop) Function

Important: *The default setting for this feature is ON. An administrator can turn off this feature in the System Settings; however, Precor recommends it remain ON.*

The Auto Stop™ (Automatic Stop) feature is designed to bring the treadmill to a gradual stop when it is not in use. This might occur if a user steps off the treadmill before the end of a workout and leaves the treadmill running.

Sixty seconds after a treadmill workout starts or resumes, the equipment begins Auto Stop monitoring. If a user is detected, then no message appears, and the selected workout continues.

If no user is detected after an additional 30 seconds, the console displays the message **NO USER DETECTED, STOPPING IN 10 SECONDS** as notification of the pending stop. During the display of this message, a ten second countdown begins. If a user does not override the countdown, the belt comes to a gradual stop after the countdown is complete.

Note: Users weighing more than 90 pounds are detected within the speed and position limits of the feature. Users weighing 50 to 89 pounds may not be detected depending on their speed and location. Always be aware of and follow the console's instructions for proper operation.

Starting a Workout

CAUTION: If you are using a treadmill, be sure to attach the security clip to your clothing before starting your workout.

The equipment is in the Welcome state when the words **SELECT A WORKOUT OR PRESS QUICKSTART TO BEGIN** scroll across the scrolling upper text display and **PRECOR** scrolls on the lower text display.

If the equipment is connected to CSAFE, the words **SELECT A WORKOUT, PRESS QUICKSTART, OR ENTER TO BEGIN** scroll across the upper text display.

If anything else appears on the screen, press **Pause** to display the Welcome banner.

From this screen, there are two ways to begin a workout:

- Press **GO** (Quick Start™ method).
This action launches the Manual program. Calculations, such as calories used, are based on a 150-lb (68 kg), 35-year old individual. You can complete a workout using this program with default values, or you can change workout settings.
- Press one of the preset workouts.

When a user reaches the club time limit during a workout, the workout limit in minutes appears before the words **CLUB TIME LIMIT REACHED, WORKOUT ENDING**, appear in the upper text display.

Starting a Preset Programmed Workout

Preset workouts are a great way to tailor your workouts to your fitness goals, stay challenged, and add variety to your sessions. The P30 includes the following preset programs depending on the type of equipment:

- Manual
- Heart Rate
- Interval
- Weight Loss
- Fat Burner
- Variety
- Performance

Setting Options

Goal, Language, and Unit options can be set before you begin a workout. Once you begin a workout or press Quick Start, you can also enter Age and Weight, and a Target Heart Rate goal.

To choose a workout goal before you begin exercising:

1. From the Welcome banner, press **OPTIONS**.
Goal is the first option.
2. To choose the Goal option, press **OK**.
Goal options are Time, Distance, and Calories.
3. Use the Up and Down arrows to increase or decrease your time, distance, or calorie goal.
4. Once you have entered a goal, press **OK**.
5. To continue to the next option category, Press **OPTIONS** again.

To choose a language setting before you begin exercising:

1. From the Welcome banner, press **OPTIONS**.
2. Press **OPTIONS** again to choose the Language option, and press **OK**.
3. Use the Up and Down arrows to navigate the list of available languages. To select a language, press **OK**.
Language choices are: English, Deutsch, Espanol, Francais, Nederlands, Portugues, Rucckijj, and Italiano.
4. To continue to the next option category, press the **Up or Down** arrows.

To choose a unit of measure before you begin exercising:

1. From the Welcome banner, press **OPTIONS**.
2. Press **OPTIONS** twice to go **UNITS**.
3. Use the Up and Down arrows to select a unit of measure.
4. Once you have selected a unit of measure, press **OK**.

Setting Options after You Begin a Workout

Once you begin a Quick Start workout or choose a Workout, you can enter your Weight and Age, and a Target Heart Rate goal. The Language and Units settings are also available.

To enter your Age and Weight during a workout:

1. Press **OPTIONS**.
2. Weight/Age is the first option. To choose this option, press **OK**.
3. Use the Up and Down arrows to increase or decrease your weight.
4. Once you have selected your weight, press **OK**.
5. Repeat steps 1 - 4 to enter your age.
6. To continue to the next option category, press the **Up or Down** arrows.

The Target Heart Rate option appears.

7. Enter a target heart rate goal, and press **OK**.

At this time, you can set Units and Language if you have not selected these options prior to beginning your workout.

Pausing and Resuming an Exercise Session

When you interrupt a workout, the equipment responds in one of two ways, depending on how it is powered.

Paused (Externally Powered Equipment)

When the session is paused, the belt speed is slowly reduced to zero, or the resistance is slowly reduced to the minimum. The lift motor is turned off leaving the incline or crossramp at its current position. Data entry is canceled.

When you press **Pause** on all non-treadmill equipment, it displays the summary screen with your workout metrics. After displaying the summary, it returns to the Welcome screen.

Pending Shutdown (Self-Powered Equipment)

On self-powered machines, the paused state is equivalent to the pending shutdown state. When you stop working out, the equipment begins a 30 second countdown.

The accumulated metrics (e.g., time, strides, distance, calories) hold their current values and do not change. Data entry may not be started.

To restart the program, begin working out again. The resistance is reset to what it was when the program was paused.

If the equipment remains inactive for more than 30 seconds, the power is lost and the equipment bypasses the workout summary screen.

Ending a Session

Cooling down is an important aspect of your workout because it helps reduce muscle stiffness and soreness by transporting excess lactic acid out of the working muscles. In addition, a three to five minute cool down allows your heart rate to return to its normal, resting state.

At the end of your workout, a Summary screen displays your average heart rate during your workout and your accumulated workout metrics.

If you performed a fitness test exercise program, an initial message presents a fitness score.

The next two messages display the user's average and maximum heart rate during the session. These messages are only displayed if heart rate data was acquired during the session, i.e., a valid heart rate number was displayed at least once during the session.

A fourth message shows the minimum and maximum heart rates that correspond to that zone. This message is only displayed if:

- The first two messages are displayed.
- The user's age has been entered.
- The user's heart rate has been in the zone for at least one second.

The summary state times out in two minutes, causing a return to the Welcome banner. If the machine is in a CSAFE Finished state then the summary state must last for at least the CSAFE timeout value, typically 10 seconds. If it has not lasted that long, then before returning to the Welcome banner, the word **RESETTING** appears until the CSAFE finished state ends.

Three different types of metrics are captured during a workout.

Controlled Metrics can be set and changed. They include:

- Resistance Level (AMT, EFX, bike)
- Speed (treadmill)
- Incline (treadmill)
- Steps/Minute (climber)

Current Performance Metrics describe the intensity of a workout in real time. They include:

- Calories/Minute, Calories/Hour
- Heart Rate
- Speed (treadmill, bike)
- Revolutions/Minute (bike)
- Strides/Minute (AMT, EFX)

Accumulated Metrics describe the overall performance throughout the entire exercise session. They include:

- Time:
 - Count-down Mode
 - Count-up Mode
- Calories
- Distance:
 - Average Strides/Minute (AMT, EFX)
 - Average Speed (treadmill, bike)
 - Floors (climber)

Programs

Preset workouts are a great way to tailor your workouts to your fitness goals, stay challenged, and add variety to your sessions. Most P30 equipment contains six preset workouts.

- Manual
- Heart Rate
- Interval
- Weight Loss
- Variety
- Performance

The one exception is the AMT. It does not contain Variety or Performance workouts, and the Weight Loss workout has been replaced with a Fat Burner workout.

Manual

In this workout, resistance and speed changes are completely under your control. The profile is initially a flat line. Any increase or decrease made in one workout segment will increase or decrease all remaining portions by the same amount.

Heart Rate

This workout computes your target heart rate based on the calculation, 60% of 220 minus your age; however, you can override this value. The equipment adjusts resistance and/or incline to maintain your target heart rate while you work out.

When a heart rate signal is not received, a heart shape with a question mark appears in the upper text display. Recheck your hand grip on the handheld sensors or the placement of your chest strap.

For the unit to detect your heart rate, you must grip the handheld heart rate sensors or wear a chest strap while exercising. In the presence of both handheld and wireless data, the handheld data takes precedence and displays.

Interval

The Interval workout is primarily for conditioning your cardiovascular system. This workout is designed to raise and lower your heart rate in a repeating fashion for a user-defined period of time by alternating rest and work intervals. Workout intensity is adjustable.

Weight Loss

The workout time is fixed at 28 minutes. The workout consists of four intervals, each lasting eight minutes. You can change the resistance at any time during the work interval.

Variety

During this workout, resistance and speed vary throughout the workout in a random pattern.

Performance

Note: When a user presses **PERFORMANCE**, the message **WORKOUT NOT AVAILABLE** will scroll in the upper text display, if the console is set to **HIDE PROGRAMS** in the Settings menu.

The Fitness Test, available by pressing the **PERFORMANCE** key, provides a means of comparing your fitness level with the official fitness test of the International Association of Firefighters (IAFF). It is written using the Gerkin Protocol, which is the basis for the official IAFF fitness test and part of their Wellness and Fitness Initiative.

During the test, the equipment gradually increases the incline and speed in specific stages. The keypads are disabled. Whatever stage you are at when the test ends determines your aerobic capacity and establishes your VO_2 max. Once you complete the test, a fitness score appears as part of the workout summary.

Maintenance

To keep the equipment functioning properly, perform the minor maintenance tasks in this section at the intervals suggested. Failure to maintain the equipment as described in this section could void the Precor Limited Warranty.

DANGER To reduce the risk of electrical shock, always disconnect the equipment from its power source before cleaning it or performing any maintenance tasks. If the equipment uses an optional power adapter, disconnect the adapter.

Cleaning the Console and Display

The console requires little maintenance once installed. Precor recommends that you clean the console before and after each exercise session.

To remove dust and dirt from the console:

- Wipe all exposed surfaces with a soft cloth that you have moistened with a solution of 30 parts of water to 1 part of Simple Green® (for more information, visit www.simplegreen.com).

Important: Do not use any acidic cleaners. Doing so will weaken the paint or powder coatings and void the Precor Limited Warranty. Never pour water or spray liquids directly on the console or console's screen.

- It is important to avoid using any corrosive chemicals on the console or screen.
- Always dampen the cloth and then clean the screen. Be sure to spray the cleaning liquid onto the cloth, not the console, so that drips do not seep into the console.
- Apply the cleaner with a soft, lint-free cloth. Avoid using gritty cloths.



Precor Incorporated
20031 142nd Avenue NE
P.O. Box 7202
Woodinville, WA USA 98072-4002

P30 OM 301096-141
18 January 2011